

estebro®

Desde 1962

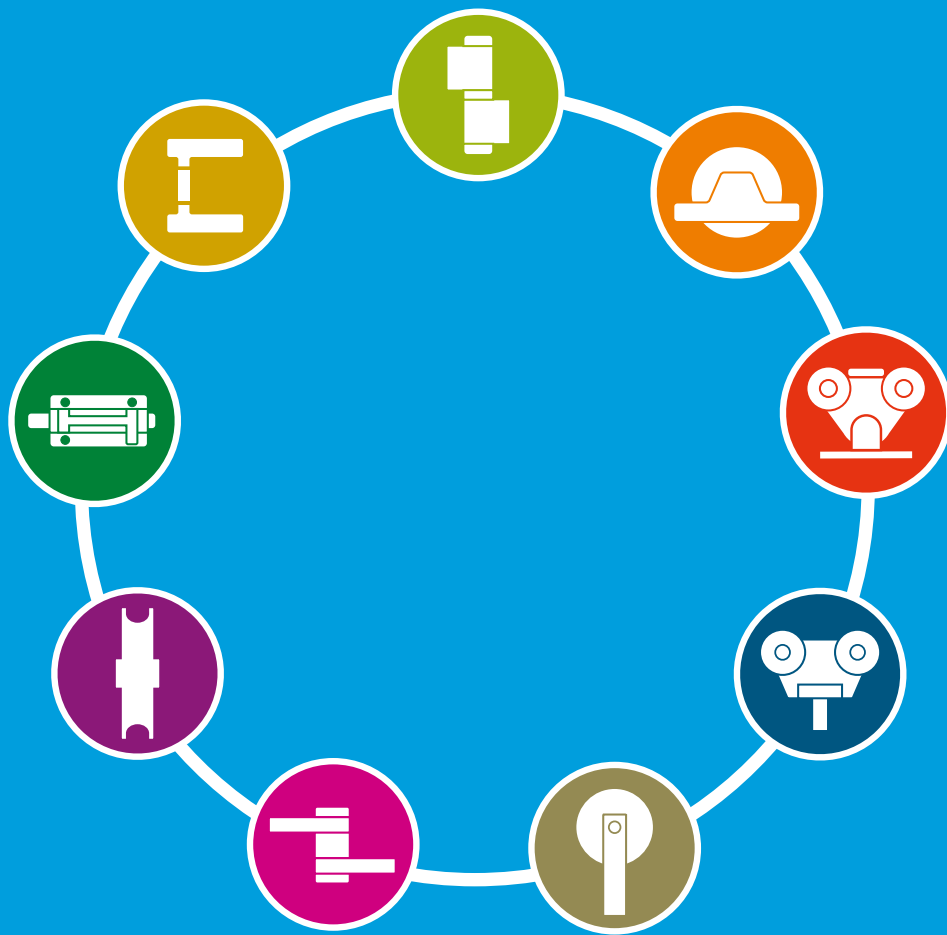

Catálogo | Catalogue

1/2025

Herrajes y Accesorios para Puertas
Gate Hardware and Accessories
Ferrures et Accessoires pour Portes
Ferragens e Accesorios para Portas



Índice

Index | Sommaire

| | |
|---|---|
|  | Empresa y servicios 4 |
| | Company and services Entreprise et services Companhia e serviços |
|  | Pernios y Bisagras 8 |
| | Hinges Paumelles et Charnières Pernos e Drobradiças |
|  | Herrajes para Puertas Correderas a Suelo 14 |
| | Bottom Sliding Gates Hardware Ferrures pour Portes Coulissantes au sol Ferragens para Portas de Correr |
|  | Herrajes para Puertas Autoportantes 20 |
| | Cantilever Gates Hardware Ferrures pour Portes Autoportantes Ferragens para Portas Autoportantes |
|  | Herrajes para Puertas Correderas Colgadas 24 |
| | Hanging Sliding Gates Hardware Ferrures pour Portes Coulissantes Suspendues Ferragens para Portas de Correr Suspensas |
|  | Herrajes para Puertas Correderas Rústicas 34 |
| | Barn Sliding Doors Hardware Ferrures pour Portes Coulissantes Rustiques Ferragens para Portas Corrediças Rusticas |
|  | Herrajes para Puertas de Cancela 38 |
| | Swing Gates Hardware Ferrures pour Portails Ferragens para Portas de Cancela |
|  | Herrajes para Puertas Elevables 40 |
| | Overhead Gates Hardware Ferrures pour Portes Basculantes Ferragens para Portas de Elevar |
|  | Cerrojos y Pasadores 42 |
| | Round and square Barrel Bolt latch Verrous ronds et Verrous Carrés Ferrolhos e Passadores |
|  | Varios 44 |
| | Other products Produits divers Varios |
|  | Manillas y Tiradores Inox 46 |
| | Stainless Steel handles and Pull handles Béquilles et Poignées Inox Manilhas e Puxadores Aço Inox |
|  | Índice de productos por código 50 |
| | Index of products by code Index des produits par code Índice por código |

ES Empresa

Desde 1962 fabricando herrajes

Desde 1962 en Estebro hemos apostado por la fabricación de calidad, la innovación, el desarrollo de nuevos productos, el buen servicio y trato a nuestros clientes.

La inversión en maquinaria de última generación, la alta preparación de nuestro equipo humano, la fabricación de nuestras propias matrices y utillajes, el control de producción, la calidad de nuestra fabricación y nuestro gran stock de producto terminado, nos permiten dar una rápida solución a los diferentes productos, tanto estándar como a medida, demandados a nivel mundial.

Garantía de Calidad

Nuestro compromiso con la calidad y la satisfacción al cliente nos lleva a cumplir con la Norma ISO-9001, garante de un sistema de gestión de calidad eficaz.



FR Entreprise

Fabricant de ferrures depuis 1962

Depuis 1962, Estebro parie sur la fabrication de qualité, l'innovation et le développement de nouveaux produits, et surtout sur le bon service à ses clients.

L'investissement en machines de dernière génération, le haut degré de préparation de notre équipe humaine, la fabrication propre de nos matrices et outillages, le contrôle de la production et qualité de nos produits, et notre gros stock de produit fini, nous permettent de donner une solution très rapide aux demandes à l'échelle mondiale, à la fois standard et sur mesure.

Garantie de Qualité

Notre compromis de qualité et satisfaction client nous mène à l'accomplissement de la norme ISO-9001, garantie d'un système efficace de gestion de la qualité.



EN Company

Hardware manufacturer since 1962

Since 1962, Estebro has been manufacturing high quality fittings. Our main goals have always been high quality production, innovation, development of new products and specially a good service to our customers.

The investment in the latest machinery, the high level of preparation of our human team, the manufacture of our own moulds and tools, the production and the quality control and our warehouse of finished products enable us to offer fast solutions to the different products requested. Both standarts and customized, on a global scale.

Quality Guarantee

Our commitment with quality and with the satisfaction of our customers leads us to fulfil with the Norm ISO-9001, guarantee of an effective quality system.



PO Companhia

Fabricando ferragens desde 1962

Desde 1962 em Estebro apostamos pela fabricação de qualidade, a inovação, o desenvolvimento de novos produtos e sobre tudo o bom serviço e trato aos clientes.

A inversao em maquinarias de ultima geração, a alta preparação da nossa equipa humana, a fabricação própia das nossas matrizes e ferramentas, o control de produção e qualidade da nossa fabricação e nosso stock de produto acabado permitem-nos dar uma rápida solução aos diferentes produtos, tanto standard como a medida, demandados a nível mundial.

Garantia de Qualidade

O nosso compromisso com a qualidade e a satisfação ao cliente levam-nos a cumprir com norma ISO-9001, garantidor de um sistema de gestao da qualidade eficaz.



Fabricación especial y a medida



Tailor - made production

Fabrication spéciale et sur mesure

Fabricação especial e sob medida

Aplicaciones para obras

Manufacture of special applications for construction sites | Fabrication d'applications spéciales pour des chantiers de construction | Aplicações especiais para obras



Fabricación de matrices y utillajes

Matrix and tools production | Fabrication de matrices et outillages | Fabricação de matrizes e ferramentas

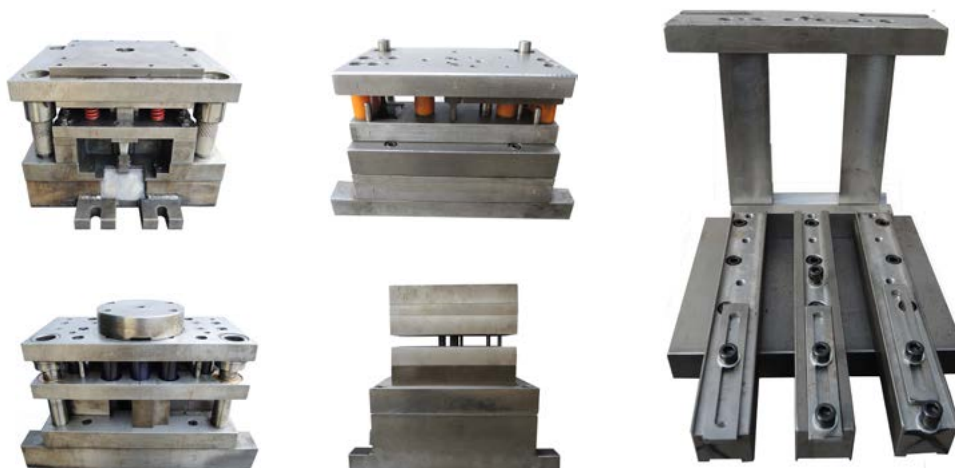

Fabricación de productos a medida

Manufacture tailor-made products | Fabrication du produits sur mesure | Fabricação de produtos sob medida

ES ¿Necesita un producto a medida?

Podemos ayudarle, somos fabricantes. Contamos con nuestra propia División de Producto Especial y a medida donde nuestros Ingenieros y Especialistas están a su disposición. Nuestra maquinaria especializada en distintos campos, cubre una gran variedad de producto a medida tanto en series largas como en series cortas.

Trabajamos con distintos tipos de **materiales, acabados y tratamientos** así como con distintos tipos de **perfiles**:

| Materiales | Acabados y Tratamientos | | Perfiles |
|---|--|---|---|
| <ul style="list-style-type: none"> • Acero • Acero Inox. • Nylon • Latón • Aluminio • Bronce • Materiales pre-tratados | <ul style="list-style-type: none"> • Bruto • Cincado • Galvanizado • Pavonado • Pulido • Pulido brillo • Lacado | <ul style="list-style-type: none"> • Satinado • Pintado • Cromado • Anodizado • Rectificado • Cementado • Templado | <ul style="list-style-type: none"> • Redondos • Gotas • Cuadrados • Hexagonales • Especiales |
| | | | |
| | | | |
| | | | |

EN Do you need a tailor-made product?

We can help you, we are manufacturer.

We have our own tailor made and special products department where our ingeneers and specialists are on your disposal.

Our machines specialized in different fields cover a large range of tailor made products for short and large production series.

We work with different types of **materials, finishes and treatments** and also different types of **profiles**:

Materials

- Steel
- Stainless steel
- Nylon
- Latón
- Aluminio
- Bronce
- Pre-treated materials

Finishes and treatments

- Gross
- Zinc
- Galvanised
- Bluing
- Polished
- Bright polished
- Lacquered
- Satin
- Painted
- Chrome
- Anocised
- Rectified
- Cemented
- Tempered

Profiles

- Round
- Drops
- Squares
- Hexagonal
- Special



FR Vous avez besoin d'un produit sur mesure?

Nous pouvons vous aider, nous sommes fabricant. Nous avons notre propre département de produit spécial et sur mesure où nos ingénieurs et spécialistes sont à votre disposition.

Notre machinerie spécialisée dans différents secteurs comprend une grande variété de produits sur mesure aussi bien de séries longues que de séries courtes.

Nous travaillons avec différents types de **matériaux, finitions et traitements** ainsi que différents types de **profils**:

Matériaux

- Acier
- Acier Inox.
- Nylon
- Laiton
- Aluminium
- Bronze
- Matériaux prétraités

Finitions et traitements

- Brut
- Zingué
- Galvanisé
- Bleui
- Poli
- Poli miroir
- Laqué
- Satiné
- Peint
- Chromé
- Anodisé
- Rectifié
- Cémenté
- Composite

Profils

- Ronds
- Gouttes
- Carrés
- Hexagonaux
- Spéciaux



PO Necessita de um produto à medida?

Nós podemos ajudá-lo, somos fabricantes.

Temos o nosso próprio departamento de produtos especiais e por medida, onde os nossos engenheiros e especialistas estão à sua disposição. As nossas máquinas especializadas em diferentes domínios cobrem uma vasta gama de produtos por medida para pequenas e grandes séries de produção. Trabalhamos com diferentes tipos de **materiais, acabamentos e tratamentos** e também com diferentes tipos de **perfis**:

Materiais

- Aço
- Aço Inox.
- Nylon
- Latón
- Aluminio
- Bronce
- Materiais pré-tratados

Acabamentos e tratamentos

- Em bruto
- Cincado
- Galvanizado
- Azulado
- Polido
- Polido brilhante
- Lacado
- Acetinado
- Pintado
- Cromado
- Anodizado
- Rectificado
- Cimentado
- Temperado

Perfis

- Rodada
- Gotas
- Quadrados
- Hexagonale
- Especial





Pernios y Bisagras

Hinges

Paumelles et Charnières

Pernos e Dobradiças

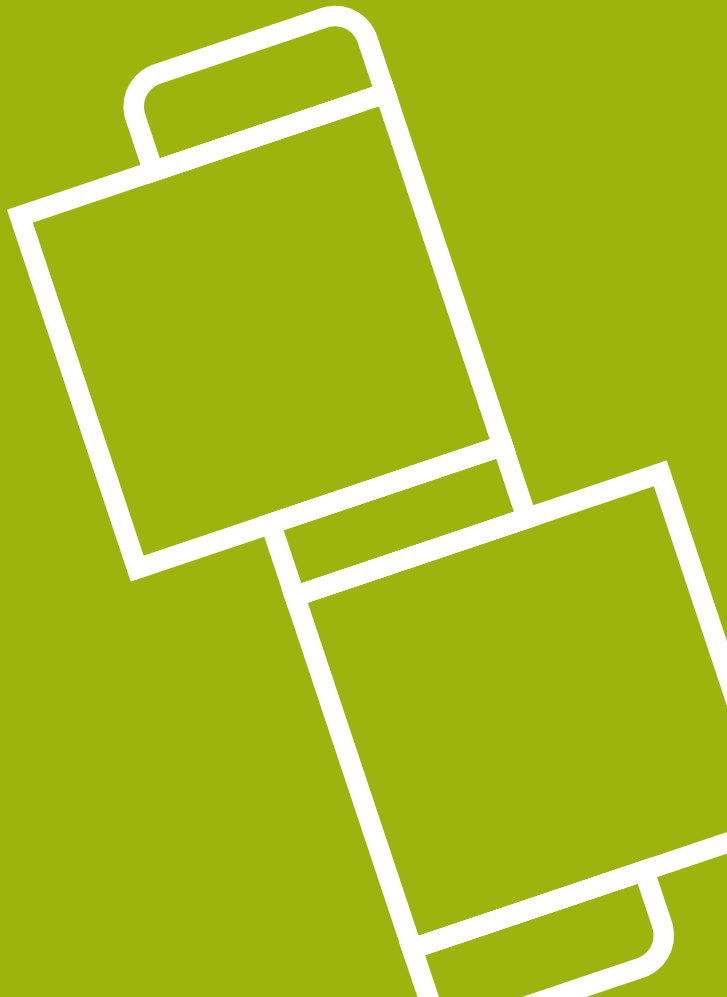

ES

Pernios torneados
Pernios gota
Pernios de pala
Pernios regulables
Pernios muelle
Pernios deslizantes
Pernios tres cuerpos
Bisagras libro
Bisagras de atornillar
Posicionador de pernios

EN

Round profile hinges
Drop profile hinges
Flag hinges
Adjustable hinges
Spring hinges
Sliding hinges
Three section hinges
Butt hinges
Hinges to screw
Hinges and butt hinges positioner

FR

Paumelles rondes
Paumelles goutte
Charnières roulées
Paumelles réglable
Paumelles avec ressort
Paumelles glissantes
Paumelles trois corps
Charnières livre
Charnières à visser
Positionneur de paumelles

PO

Pernos torneados
Pernos gota
Dobradiças em forma de "pá"
Pernos reguláveis
Pernos mola
Pernos deslizantes
Pernos três corpos
Dobradiças livro
Dobradiças de parafusar
Posicionador de dobradiças

A
CERO
STEEL
ACIER
AÇO

I
NOX
STAINLESS
STEEL

Pernios torneados

Round profile hinges | Paumelle profil rond | Pernos torneados



Con arandela de latón | With brass washer | Avec bague laiton | Com anilha de latão

| Cod. | Medidas - Dimensions | |
|--|----------------------|-----|
| 31 | 8x50 | 100 |
| 1 | 10x60 | 60 |
| 4 | 12x70 | 45 |
| 5 | 12x80 | 45 |
| 6 | 14x80 | 28 |
| 7 | 14x100 | 24 |
| 8 | 16x80 | 24 |
| 9 | 16x100 | 35 |
| 32 | 16x100 Engrasador | 35 |
| 10 | 16x120 | 30 |
| 33 | 16x120 Engrasador | 30 |
| 11 | 18x100 | 30 |
| 12 | 18x110 | 24 |
| 13 | 18x120 | 24 |
| 14 | 20x100 | 24 |
| 15 | 20x120 | 20 |
| 16 | 22x120 | 16 |
| 17 | 25x120 | 12 |
| 18 | 25x150 | 12 |
| 19 | 30x150 | 8 |
| 20 | 30x200 | 12 |
| 21 | 35x150 | 6 |
| 22 | 35x200 | 12 |
| Inox Stainless Steel AISI 303 | | |
| 86 | 8x50 | 20 |
| 79 | 10x60 | 20 |
| 84 | 12x70 | 20 |
| 80 | 14x80 | 14 |
| 81 | 16x100 | 15 |
| 82 | 18x110 | 12 |
| 83 | 20x120 | 10 |
| 85 | 25x150 | 6 |
| 286 | 30x150 | 4 |
| Inox Stainless Steel AISI 316 | | |
| 280 | 12x70 | 20 |
| 281 | 16x100 | 15 |
| 282 | 20x120 | 10 |
| 283 | 25x150 | 6 |
| Inox Pulido Polished Poli Polido AISI 303 | | |
| 81P | 16x100 | 15 |
| 83P | 20x120 | 10 |
| 85P | 25x150 | 6 |



Con rodamiento axial | With axial bearing | Avec roulement à billes | Com rolamento axial

| Cod. | Medidas - Dimensions | |
|--|----------------------|----|
| 272 | 14x80 | 28 |
| 273 | 16x100 | 35 |
| 30 | 20x120 | 20 |
| 274 | 22x120 | 16 |
| 27 | 25x120 | 12 |
| 28 | 25x150 | 12 |
| 29 | 30x150 | 8 |
| 291 | 30x150 Pistas | 8 |
| 496 | 35x150 Pistas | 6 |
| 495 | 35x200 Pistas | 12 |
| 490 | 40x160 Pistas | 6 |
| Inox Stainless Steel AISI 303 | | |
| 8012 | 14x80 | 14 |
| 8111 | 16x100 | 15 |
| 831 | 20x120 | 10 |
| 851 | 25x150 | 6 |
| Inox Stainless Steel AISI 316 | | |
| 81110 | 16x100 | 15 |
| 284 | 20x120 | 10 |
| 285 | 25x150 | 6 |
| Inox Pulido Polished Poli Polido AISI 303 | | |
| 8111P | 16x100 | 15 |
| 831P | 20x120 | 10 |
| 851P | 25x150 | 6 |



Con bola | With ball | Avec bille | Com bola

| Cod. | Medidas - Dimensions | |
|------|----------------------|----|
| 23 | 20x120 | 20 |
| 24 | 25x120 | 12 |
| 25 | 25x150 | 12 |
| 26 | 30x150 | 8 |
| 494 | 30x200 | 12 |
| 489 | 35x150 | 6 |
| 493 | 35x200 | 12 |
| 492 | 40x160 | 6 |
| 491 | 40x200 | 6 |



Video

Deslizante | Sliding | Glissante | Deslizante

| Cod. | Medidas - Dimensions | |
|------|----------------------|----|
| 40 | 20x120 | 20 |



Video

INOX - SS

Regulable | Regulating | Réglable | Regulável

| Cod. | Medidas - Dimensions | |
|--|----------------------|----|
| 613 | 20x120 M.10 | 20 |
| 614 | 25x150 M.10 | 12 |
| 615 | 30x150 M.12 | 8 |
| Inox Stainless Steel AISI 303 | | |
| 624 | 20x100 M.10 | 12 |
| 625 | 25x150 M.10 | 6 |



Video

Con muelle | With spring | À ressort | Com mola

| Cod. | Medidas - Dimensions | |
|---|-----------------------------|----|
| 34IZ | 25x120 Izd Left Gauche | 12 |
| 34D | 25x120 Dch Right Droite | 12 |
| Inox Stainless Steel AISI 316 | | |
| Inox Pulido Polished Poli Polido | | |
| 35IZ | 25x120 Izd Left Gauche | 2 |
| 35D | 25x120 Dch Right Droite | 2 |

Engrasador | Greaser | Graisseur | Engraxador

Pernios Torneados: Pernos Ø16 con o sin engrasador. Pernos Ø18 en adelante todos con engrasador.
Pernios Gota: Pernos Ø16 en adelante todos con engrasador.

Round Profile: Hinges Ø16 with or without greaser. From Ø18 hinges, grease hole always included.
Drop Profile: From Ø16 hinges, grease hole always included.

Profil Rond: Paumelles Ø16 avec/sans graisse. À partir de Ø18 graisseur toujours inclus.
Profil Goutte: Paumelles à partir de Ø16 graisseur toujours inclus.

Pernos Torneados: Ø16 com/sem engraxador. Pernos Ø18 en adelante todos con engraxador.
Pernos Gota: Pernos a partir de Ø16 todos com engraxador.



Pernios perfil gota

Drop profile hinges | Paumelles profil goutte | Pernos perfil gota



Con arandela de latón | With brass washer | Avec bague laiton | Com anilha de latão

| Cod. | Medidas - Dimensions | |
|---|----------------------|-----------------|
| 42 | 10x45 | 60 |
| 43 | 10x60 | 60 |
| 44 | 14x80 | 28 |
| 45 | 14x100 | 24 |
| 46 | 16x100 | 35 |
| 47 | 16x120 | 30 |
| 48 | 20x120 | 18 |
| 513 | 20x140 | 15 |
| 49 | 20x150 | 15 |
| 514 | 20x160 | 12 |
| 59 | 23x150 | 12 |
| 71 | 23x180 | 10 |
| Inox Stainless Steel | | AISI 316 |
| 708 | 10x60 | 20 |
| 709 | 14x80 | 15 |
| 710 | 16x80 | 15 |
| 711 | 16x100 | 15 |
| 712 | 20x120 | 10 |
| 713 | 20x150 | 8 |
| 714 | 23x150 | 6 |
| 715 | 23x180 | 5 |
| Inox Pulido Polished Poli Polido | | AISI 316 |
| 711P | 16x100 | 15 |
| 712P | 20x120 | 10 |
| 714P | 23x150 | 6 |



Con arandela inox | With stainless steel washer | Avec bague inox | Com anilha inox

| Cod. | Medidas - Dimensions | |
|-------------------------------|----------------------|-----------------|
| Inox Stainless Steel | | AISI 316 |
| 628 | 16x80 | 15 |
| 629 | 16x100 | 15 |
| 728 | 20x120 | 10 |
| 729 | 20x150 | 8 |



Engrasador
Greaser | Graisseur | Engraxador



Pernios Torneados: Pernos Ø16 con o sin engrasador. Pernos Ø18 en adelante todos con engrasador.
Pernios Gota: Pernos Ø16 en adelante todos con engrasador.



Round Profile: Hinges Ø16 with or without greaser. From Ø18 hinges, grease hole always included.
Drop Profile: From Ø16 hinges, grease hole always included.



Profil Rond: Paumelles Ø16 avec/sans graisse. À partir de Ø18 graisseur toujours inclus.
Profil Goutte: Paumelles à partir de Ø16 graisseur toujours inclus.



Pernos Torneados: Ø16 com/sem engraxador. Pernos Ø18 en adelante todos con engraxador.
Pernos Gota: Pernos a partir de Ø16 todos com engraxador.



Con rodamiento axial | With axial bearing | Avec roulement à billes | Com rolamento axial

| Cod. | Medidas - Dimensions | |
|---|----------------------|-----------------|
| 53 | 14x80 | 28 |
| 54 | 14x100 | 24 |
| 55 | 16x100 | 35 |
| 56 | 16x120 | 25 |
| 57 | 20x120 | 18 |
| 581 | 20x140 | 15 |
| 58 | 20x150 | 15 |
| 72 | 23x150 | 12 |
| 73 | 23x180 | 8 |
| Inox Stainless Steel | | AISI 316 |
| 720 | 14x80 | 15 |
| 721 | 16x80 | 15 |
| 722 | 16x100 | 15 |
| 723 | 20x120 | 10 |
| 724 | 20x150 | 8 |
| 725 | 23x150 | 6 |
| 726 | 23x180 | 5 |
| Inox Pulido Polished Poli Polido | | AISI 316 |
| 722P | 16x100 | 15 |
| 723P | 20x120 | 10 |
| 725P | 23x150 | 6 |



Vídeo

INOX - SS

Regulable
Adjustable | Réglable | Regulável

| Cod. | Medidas - Dimensions | |
|-------------------------------|----------------------|-----------------|
| 617 | 14x80 | M.6 21 |
| 618 | 16x100 | M.8 15 |
| 619 | 20x120 | M.10 18 |
| 620 | 23x150 | M.10 12 |
| Inox Stainless Steel | | AISI 316 |
| 626 | 20x120 | M.10 10 |
| 627 | 23x150 | M.10 6 |



Regulable 3D
3D Adjustable | Réglable 3D | Regulável 3D

| Cod. | Medidas - Dimensions | |
|-------------------------------|----------------------|-----------------|
| 287 | 16x120 | 2 |
| Inox Stainless Steel | | AISI 316 |
| 288 | 16x120 | 2 |



Perno regulable 3D
Permite regular la altura y el desplazamiento de la puerta, mediante llaves Allen. Una vez conseguida la posición deseada, se fija mediante prisioneros laterales. Este perno nos permite regular las puertas en 3 direcciones:

X: Regulación en X hasta 1 mm
Y: Regulación en Y de 0 a 3,5 mm
Z: Regulación en Z hasta 0,5 mm



Paumelle réglable 3D
C'est permet d'ajuster la hauteur et de faire bouger la porte, à l'aide de clefs Allen. Une fois que la position souhaitée est atteinte, la paumelle se fixe à l'aide de vis de fixation latérales. Permet un réglage sur 3 dimensions:

X: Ajustement en X jusqu'à 1 mm
Y: Ajustement en Y de 0 à 3,5 mm
Z: Ajustement en Z jusqu'à 0,5 mm



Vídeo

Con muelle
With spring | À ressort | Con mola

| Cod. | Medidas - Dimensions | |
|------|----------------------|---|
| 276 | 22x250 | 8 |



Regulating 3D Drop Profile Hinge
Allows to regulate the height and the movement of the door through Allen wrenches. Once the desired sitting is reached, the hinge is fixed through side fastening screws. The hinge allows 3 ways of regulation:

X: Regulation in X up to 1 mm
Y: Regulation in Y from 0 to 3,5 mm
Z: Regulation in Z up to 0,5 mm



Perno regulável 3D
Permite regular a altura e o movimento da porta, utilizando uma chave Allen. Uma vez alcançada a posição desejada, é fixada por prisioneiros laterais. Esta dobradiça permite regular as portas em 3 direções:

X: Ajuste em X até 1 mm
Y: Ajuste em Y de 0 a 3,5 mm
Z: Ajuste em Z até 0,5 mm

Pernios de pala

Flag hinges | Paumelles roulées | Dobradiças en forma de "pa"



Z
INCADO
ZINC
ZINGÉ
ZINCADO

Corta

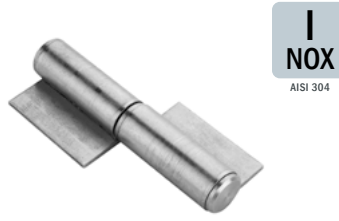

I
NOX
AISI 304



Vídeo

Pernio de pala | Flag hinge | Paumelle roulée | Dobradiça de "pa"

| Cod. | Medidas - Dimensions | | |
|---|-------------------------------------|-----|----|
| Eje Zincado Zinc plated axle Axe zingué Eixo zincado | | | |
| 60 | 60R 10x60x2 | 100 | 40 |
| 61 | 61R 12x80x2 | 80 | 30 |
| 62 | 62R 14x80x3 | 50 | 20 |
| 63 | 63R 16x100x3 | 50 | 24 |
| 64 | 64R 18x110x4 | 40 | 16 |
| 65 | 65R 20x120x5 | 30 | 12 |
| 66 | 66R 25x120x5 | 24 | 10 |
| 67 | 67R 30x150x6 | 24 | 8 |
| 68 | 68R 12x80x2 Corta Short Courte | 100 | 40 |
| 69 | 69R 14x80x3 Corta Short Courte | 90 | 24 |
| 70 | 70R 16x100x3 Corta Short Courte | 60 | 30 |
| Zincado completo Zinc plated Zingué Zincado | | | |
| 60Z | 10x60x2 Zn | 100 | |
| 61Z | 12x80x2 Zn | 80 | |
| 62Z | 14x80x3 Zn | 50 | |
| 63Z | 16x100x3 Zn | 50 | |
| 64Z | 18x110x4 Zn | 40 | |
| 65Z | 20x120x5 Zn | 30 | |
| 66Z | 25x120x5 Zn | 24 | |
| 67Z | 30x150x6 Zn | 24 | |
| 68Z | 12x80x2 Zn Corta Short Courte | 100 | |
| 69Z | 14x80x3 Zn Corta Short Courte | 90 | |
| 70Z | 16x100x3 Zn Corta Short Courte | 60 | |

Inox AISI 304L | Stainless steel flag hinge | Charnière roulée inox | Dobradiça de "pa" inox

| Cod. | Medidas - Dimensions | |
|--|-------------------------------|----|
| Inox Stainless Steel AISI 304 | | |
| 602 | 12x80x2 Izq Left Gauche | 18 |
| 603 | 12x80x2 Dch Right Droite | 18 |
| 604 | 18x100x3 Izq Left Gauche | 12 |
| 605 | 18x100x3 Dch Right Droite | 12 |
| 606 | 20x140x3 Izq Left Gauche | 6 |
| 607 | 20x140x3 Dch Right Droite | 6 |
| Inox Pulido Polished Poli Polido AISI 304 | | |
| 602P | 12x80x2 Izq Left Gauche | 18 |
| 603P | 12x80x2 Dch Right Droite | 18 |
| 604P | 18x100x3 Izq Left Gauche | 12 |
| 605P | 18x100x3 Dch Right Droite | 12 |
| 606P | 20x140x3 Izq Left Gauche | 6 |
| 607P | 20x140x3 Dch Right Droite | 6 |

Con rodamiento axial | With axial bearing | Avec roulement à billes | Com rolamento axial

| Cod. | Medidas - Dimensions | |
|--|-------------------------------|----|
| Zincado completo Zinc plated Zingué Zincado | | |
| 503 | 20x120x4 Izq Left Gauche | 30 |
| 504 | 20x120x4 Dch Right Droite | 30 |
| 505 | 20x150x4 Izq Left Gauche | 12 |
| 506 | 20x150x4 Dch Right Droite | 12 |
| 507 | 25x150x5 Izq Left Gauche | 8 |
| 508 | 25x150x5 Dch Right Droite | 8 |
| Inox Stainless Steel AISI 304 | | |
| 608 | 18x110x3 Izq Left Gauche | 12 |
| 609 | 18x110x3 Dch Right Droite | 12 |
| 610 | 20x150x3 Izq Left Gauche | 6 |
| 611 | 20x150x3 Dch Right Droite | 6 |
| Inox Pulido Polished Poli Polido AISI 304 | | |
| 608P | 18x110x3 Izq Left Gauche | 12 |
| 609P | 18x110x3 Dch Right Droite | 12 |
| 610P | 20x150x3 Izq Left Gauche | 6 |
| 611P | 20x150x3 Dch Right Droite | 6 |



Z
INCADO
ZINC
ZINGÉ
ZINCADO

Pernio pala larga
Long flag hinge
Paumelle roulée longue
Dobradiça en forma de "pa"

| Cod. | Medidas - Dimensions | |
|---|----------------------|----|
| Eje Zincado Zinc plated axle Axe zingué Eixo zincado | | |
| 68072 | 14x80x3 Larga | 20 |
| 68074 | 16x100x3 Larga | 20 |



Z
INCADO
ZINC
ZINGÉ
ZINCADO

Pernio pala 3 cuerpos con arandela de latón
3 sections flag hinge with brass washer
Paumelle roulée 3 corps avec bague laiton
Dobradiça 3 corpos com anilha de latão

| Cod. | Medidas - Dimensions | |
|---|----------------------|----|
| Eje Zincado Zinc plated axle Axe zingué Eixo zincado | | |
| 4191 | 16x160x3 Larga | 20 |



Z
INCADO
ZINC
ZINGÉ
ZINCADO

Pernio pala 3 cuerpos
3 sections flag hinge
Paumelle roulée 3 corps
Dobradiça 3 corpos

| Cod. | Medidas - Dimensions | |
|--|----------------------|---|
| Zincado completo Zinc plated Zingué Zincado | | |
| 68080 | 185x180x6 | 8 |

Pernios tres cuerpos

Three section hinges | Paumelles trois corps | Dobradiças três corpos



| Cod. | Medidas - Dimensions | |
|------|----------------------|----|
| 50 | 16x100 | 30 |
| 51 | 20x120 | 20 |
| 52 | 25x150 | 12 |
| 390 | 30x175 | 12 |
| 391 | 35x175 | 6 |

Inox AISI 303 | Stainless steel

| Cod. | Medidas - Dimensions | |
|--|----------------------|----|
| Inox Stainless Steel AISI 303 | | |
| 510 | 16x100 | 15 |
| 511 | 20x120 | 10 |
| 512 | 25x150 | 6 |





PERNIOS Y BISAGRAS

HINGES | PAUMELLES ET CHARNIÈRES | PERNOS E DROBRADIÇAS

Bisagras

Butt hinges | Charnières | Dobradiças



Z
INCADO
ZINC
ZINGÉ
ZINCADO



I
NOX
AISI 304

Bisagra libro | Butt hinges | Charnières livre | Dobradiças libro

| Cod. | Medidas - Dimensions | |
|-------------------------------|----------------------|-----------------|
| 195R | 80 mm | 20 |
| 196R | 100 mm | 12 |
| 197R | 150 mm | 10 |
| Inox Stainless Steel | | AISI 304 |
| 1950 | 80 mm | 20 |
| 1960 | 100 mm | 12 |
| 1970 | 150 mm | 10 |

Bisagra libro cincada | Zinc plated butt hinges | Charnières livre zingué | Dobradiças libro zn

| Cod. | Medidas - Dimensions | |
|--|----------------------|----|
| Zincado completo Zinc plated Zingué Zincado | | |
| 195RZ | 80 mm | 20 |
| 196RZ | 100 mm | 12 |
| 197RZ | 150 mm | 10 |

Bisagra atornillar rodamiento | Butt hinge to screw with bearing | Charnières a visser avec roulement billes | Parafusar com rolamento

| Cod. | Medidas - Dimensions | |
|-------------------------------|----------------------|-----------------|
| Inox Stainless Steel | | AISI 304 |
| 520SS | 100x75x2,5 | 2 |
| 525SS | 100x100x2,5 | 2 |

Posicionador de pernios y bisagras

Hinges and butt hinges positioner | Positionneur de paumelles et de charnières | Posicionador de dobradiças e pernos

ES

Características

- Cumple la directiva 2001/95/CE
- Se usa sólo para puntear la posición del pernio, no para la soldadura total.
- Optimizador de tiempo.
- Válido para gran variedad de medidas y modelos de bisagras.
- No requiere especialización para su uso.

EN

Characteristics

- Meet the requirements of the directive 2001/95/CE
- It is only used to point the position of the hinge, not for the whole welding.
- Time saver.
- Valid for a wide range of hinges dimensions and types.
- No need to have any specializations for its use.

FR

Caractéristiques

- Répond aux exigences de la directive 2001/95/CE
- S'utilise pour pointer la position de la paumelle, non pour la soudure totale.
- Optimiseur de temps.
- Valable pour une large gamme de dimensions et de modèles de charnières.
- Aucun besoin de spécialisations pour son utilisation.

PO

Características

- Conformidade com a Diretiva 2001/95/CE
- Usado apenas para perfurar a posição do parafuso, não para soldadura completa.
- Optimizador de tempo.
- Válido para uma grande variedade de tamanhos e modelos de dobradiças.
- Não é necessária especialização para utilização.



A
CCESORIO
ACCESSORY
ACCESSOIRE



A
CCESORIO
ACCESSORY
ACCESSOIRE

Posicionador de pernios y bisagras
Hinges and butt hinges positioner | Positionneur de paumelles | Posicionador de dobradiças

| Cod. | Medidas - Dimensions | |
|-------|----------------------|---|
| PO-01 | 280x125x37 | 1 |

Set de centralizadores M4
Set of centralizers | Jeu de centreurs | Conjunto de centragem

| Cod. | Medidas - Dimensions | |
|---------|----------------------|---|
| PO-0106 | Ø 6 mm | 1 |
| PO-0107 | Ø 7 mm | 1 |
| PO-0108 | Ø 8 mm | 1 |

Set de bases con imán
Set of bases with magnet | Jeu de bases avec aimant | Conjunto de base con imã

| Cod. | Set Jeu Jogo | |
|---------|------------------|---|
| PO-0120 | Set Jeu Jogo | 1 |

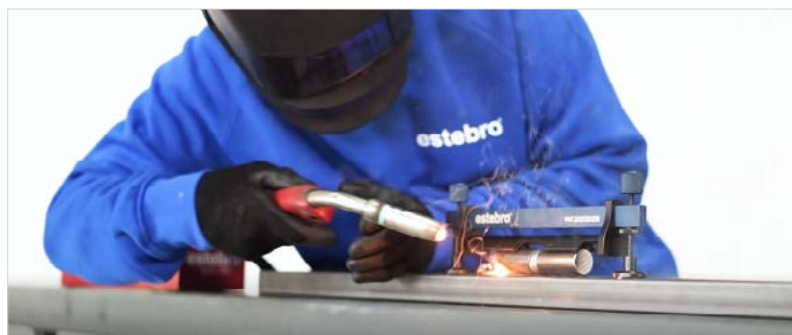

Vídeo

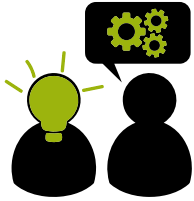

SOFTWARE PROPIO DE ASESORAMIENTO

OWN ADVICE SOFTWARE | PROPRE LOGICIEL DE CONSEIL | PRÓPRIO SOFTWARE CONSULTIVO

ES ¿Dudas en la instalación de sus puertas?

Consúltenos.

Trabajemos juntos para lograr la solución óptima.

En Estebro contamos con nuestro propio software de asesoramiento.

¿Qué ofrece nuestro software?

Conociendo las características básicas de una puerta, como peso y dimensiones, proponemos la solución más óptima:

- Qué elementos debe colocar (tipo y tamaño).
- A qué distancias fijarlos.

Habiendo determinado por nuestra parte un coeficiente de seguridad suficientemente alto como para poder absorber incluso el efecto fatiga.

Nuestros clientes pueden colocar nuestros herrajes con la seguridad y tranquilidad de no tener problemas por resistencia (en perfectas condiciones de instalación, uso y mantenimiento).

Estebro proporciona a sus clientes una solución segura para sus instalaciones.

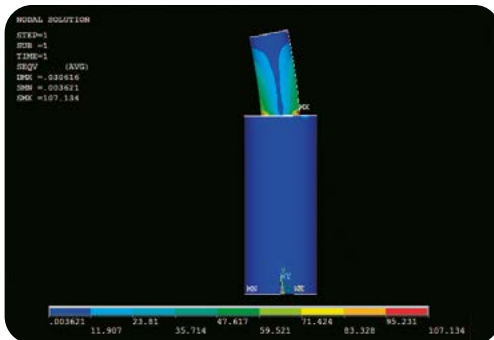

EN You have doubts about the installation of your doors?

Consult us.

We will work together to achieve the optimal solution.

In Estebro, we have our own advice software.

What does that software provide you?

By knowing the basic characteristics of a door, like weight and dimensions, we offer the best solution and can indicate you:

- Which elements you should install (type and dimension).
- The distances where to fix them.

Once a high security coefficient has been identified by us able to absorb the fatigue effect. Our clients can install our hardware with the security and tranquility of having no problems with the resistance.

Estebro provides its clients with the safest solutions for their system installations.

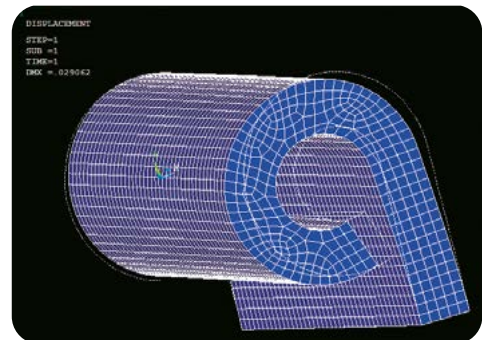

FR Vous avez des questions sur l'installation de vos portes?

Consultez-nous.

Nous travaillerons ensemble pour trouver la meilleure solution.

Chez Estebro, nous comptons sur notre propre programme logiciel de conseil.

Qu'est ce que notre logiciel apporte?

En connaissant les caractéristiques basiques d'une porte, avec poids et dimensions, nous proposons la meilleure solution possible:

- Quels éléments vous devriez installer (type et dimensions).
- À quelles distances les fixer.

Nous avons déterminé un coefficient de sécurité suffisamment élevé afin de pouvoir amortir l'effet de fatigue. Nos clients peuvent installer nos ferrures en toute sécurité et tranquillité, sans se préoccuper de possibles problèmes de résistance (dans de parfaites conditions d'installation, utilisation et maintenance).

Estebro offre à ses clients une solution sûre pour leurs installations.

PO Dúvidas na instalação das suas portas?

Contacte-nos.

Trabalharemos em conjunto para alcançar a solução ideal.

Na Estebro temos o nosso próprio software consultivo.

O que o nosso software oferece?

Conhecendo as características básicas de uma porta, como peso e dimensões, propomos a solução mais ideal:

- Que elementos deve colocar (tipo e tamanho).
- A que distâncias os fixar.

Tendo determinado de nossa parte um coeficiente de segurança alto o suficiente para ser capaz de absorver até mesmo o efeito da fadiga.

Os nossos clientes podem colocar as nossas ferragens com a segurança e tranquilidade de não ter problemas devido à resistência (em perfeitas condições de instalação, utilização e manutenção).

A Estebro oferece aos seus clientes uma solução segura para as suas instalações.



Herrajes Puertas Correderas a Suelo

Bottom Sliding Gates Hardware

Ferrures Portes Coulissantes au Sol

Ferragens Portas de Correr



Carriles y Cremalleras
Poleas guía
Cajas de poleas guía
Poleas "U" y "V"
Poleas Tandem Doble
Poleas caja de aluminio
Polea pivotante
Cerraduras de gancho
Cajas para cerradura
Tiradores y topes



Tracks and Racks
Rollers
Adjustable guide plates
"U" and "V" groove wheels
Twin Wheels
Wheels with aluminum box
Pivot wheel
Hook locks
Cover box for locks
Pullers and stoppers



Rails et Cremaillères
Olive de guidage
Plaques guide
Roues "U" et "V"
Tandem Double
Support en aluminium
Roue pivotante
Serrure à crochet
Couverture serrure
Tiroirs et arrêts



Trilhos e Cremalheiras
Polias guia
Caixa de polias guia
Polias "U" e "V"
Tandem duplo
Polias caixa alumínio
Polia pivot
Fechaduras de gancho
Caizas para fechaduras
Puxadores e topes





Carril empotrado mariposa "U" 20 mm
Track to fit | Rail à sceller | Trilho embutir

| Cod. | Medidas - Dimensions | ±1% |
|-------------------------------|----------------------|-----------------|
| 533 | U-20 Galvanizado | 3 m |
| Inox Stainless Steel | | AISI 304 |
| 530 | U-20 | 3 m |

Empalme gratis cada 2 barras de 3 m
Free joint for rails every 2 rails of 3 m
Joints gratuits pour chaque 2 barres de 3 m
Conexão grátis cada 2 barras de 3 m

Cod.522

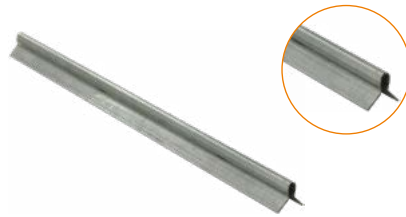

Carril empotrado mariposa "U" 20 mm sin agujero
Track to fit | Rail à sceller | Trilho embutir

| Cod. | Medidas - Dimensions | ±1% |
|------|----------------------|-----|
| 5330 | U-20 Galvanizado | 3 m |

Empalme gratis cada 2 barras de 3 m
Free joint for rails every 2 rails of 3 m
Joints gratuits pour chaque 2 barres de 3 m
Conexão grátis cada 2 barras de 3 m

Cod.522



Carril empotrado "U"
Track to fit | Rail à seller | Trilho embutir

| Cod. | Medidas - Dimensions | ±1% |
|-------------------------------|----------------------|-----------------|
| 536 | U-20 Galvanizado | 3 m |
| 540 | U-16 Galvanizado | 3 m |
| Inox Stainless Steel | | AISI 304 |
| 5404 | U-16 | 3 m |

Empalme gratis cada 2 barras de 3 m
Free joint for rails every 2 rails of 3 m
Joints gratuits pour chaque 2 barres de 3 m
Conexão grátis cada 2 barras de 3 m

Cod.519 U-20
Cod.520 U-16



Empalme carril empotrado | Joint track to fit | Joint rail à sceller | Conexão trilho embutir

| Cod. | Para carril For track Pour rail Para trilho | ±1% |
|-------------------------------|--|-----------------|
| 522 | Para carril 533 y 5330 | 1 |
| 519 | Para carril 536 | 1 |
| 520 | Para carril 540 | 1 |
| Inox Stainless Steel | | AISI 303 |
| 524 | Para carril 530 | 1 |
| 523 | Para carril 5404 | 1 |

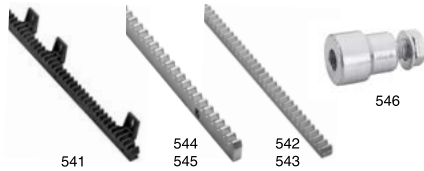

Carril atornillar "U"
Track to screw | Rail à visser | Trilho parafusar

| Cod. | Medidas - Dimensions | ±1% |
|-------------------------------|----------------------|-----------------|
| 535 | U-20 Galvanizado | 3 m |
| 539 | U-16 Galvanizado | 3 m |
| Inox Stainless Steel | | AISI 304 |
| 531 | U-20 | 3 m |
| 5391 | U-16 | 3 m |

Consultar rail sin punzonar



Carril atornillar "V" 20 mm | Track to screw | Rail à visser | Trilho parafusar

| Cod. | Medidas - Dimensions | ±1% |
|-------------------------------|----------------------|-----------------|
| 537 | V-20 | 3 m |
| Inox Stainless Steel | | AISI 304 |
| 532 | V-20 | 3 m |

Consultar rail sin punzonar



Cremallera módulo 4 | Rack mod.4 | Crémaillère mod.4 | Cremalheira mod.4

| Cod. | Medidas - Dimensions | ±1% |
|-------|----------------------|-----|
| 541 * | Nylon 20x28 | 1 m |
| 544 * | Atornillar 12x30 | 1 m |
| 545 * | Atornillar 12x30 | 2 m |
| 542 | Soldar 20x20 | 1 m |
| 543 | Soldar 20x20 | 2 m |
| 546 | Tornillo 30x12 | 1 |

* Tornillos gratis. 1 m = 3 un, 2 m = 4 un
* Free screws. 1 m = 3 screws, 2 m = 4 screws
* Vis gratuites. 1 m = 3 vis, 2 m = 4 vis
* Parafusos gratis. 1 m = 3 un, 2 m = 4 un



Polea guía nylon | Nylon roller | Olive de guidage | Polia guía de nylon

| Cod. | Medidas - Dimensions | ±1% |
|-------------------------------|-------------------------|-----------------|
| 700 | 25x35 M.12 | 24 |
| 7003 * | 25x35 M.12 | 24 |
| 133 | 30x30 M.16 | 36 |
| 132 | 35x35 M.16 | 25 |
| 134 | 40x40 M.16 | 20 |
| 1342 | 40x40 M.16 Largo Long | 20 |
| 701 | 40x60 M.16 | 16 |
| Inox Stainless Steel | | AISI 303 |
| 1332 | 30x30 M.16 | 12 |
| 1321 | 35x35 M.16 | 10 |
| 1341 | 40x40 M.16 | 8 |

* Polea guía ajustable con tornillo desmontable | Adjustable Roller with Removable Threaded rod | Olive de guidage réglable avec tige filetée amovible | Polia guia regulável com haste roscada amovível

Polea guía nylon largo | Long nylon roller | Olive de guidage longue | Polia guía nylon longa

| Cod. | Medidas - Dimensions | ±1% |
|------|----------------------|-----|
| 1901 | 35x150 M.16 | 6 |
| 1902 | 35x250 M.16 | 6 |



1612-16121

1673-16730

Caja de poleas guía simple regulable
Adjustable simple guide bracket | Plaque guide | Caixa regulável

| Cod. | Medidas - Dimensions | ±1% |
|-------------------------------|----------------------|-----------------------|
| 161 | ∅ 30 6-94 | 12 |
| 1614 | ∅ 35 11-89 | 12 |
| Inox Stainless Steel | | AISI 303 - 304 |
| 306 | ∅ 30 6-94 | 4 |



Caja de poleas regulable
Adjustable double guide bracket | Plaque guide | Caixa regulável

| Cod. | Medidas - Dimensions | ±1% |
|-------------------------------|----------------------|-----------------------|
| 167 | ∅ 30 30-65 | 6 |
| 1675 | ∅ 35 25-60 | 6 |
| 171 | ∅ 40 58-92 | 6 |
| Inox Stainless Steel | | AISI 303 - 304 |
| 358 | ∅ 30 30-65 | 4 |
| 359 | ∅ 40 58-92 | 1 |



Caja de poleas guía regulable a pared
Wall mounted guide bracket | Plaque guide | Caixa regulável

| Cod. | Medidas - Dimensions | ±1% |
|-------------------------------|----------------------|-----------------------|
| 1612 | ∅ 40 20-100 | 2 |
| 1673 | ∅ 40 20-76 | 4 |
| Inox Stainless Steel | | AISI 303 - 304 |
| 16121 | ∅ 40 20-100 | 2 |
| 16730 | ∅ 40 20-76 | 4 |



HERRAJES PUERTAS CORREDERAS A SUELO

BOTTOM SLIDING GATES HARDWARE | FERRURES PORTES COULISSANTES AU SOL | FERRAGENS PORTAS DE CORRER



Tapa de seguridad para poleas guía | Security cover nylon rollers | Couverture de sécurité pour plaques guide | Tampa segurança polias guia

| Cod. | Para For Pour | |
|-------|-------------------|----|
| 1674 | 35x35 | 10 |
| 17100 | 40x40 | 10 |



Polea guía en hierro | Steel guide sheave | Guide acier | Polia guia ferro

| Cod. | Medidas - Dimensions | | |
|------|----------------------|------|----|
| 130 | 42 mm | U-50 | 12 |
| 131 | 52 mm | U-60 | 12 |
| 1311 | 72 mm | U-80 | 1 |



Freno hidraulico ajustable cremallera M4
Hydraulic brake for rack | Frein hydraulique pour crémaillère | Freio hidráulico

| Cod. | Medidas - Dimensions | |
|--------|----------------------|---|
| 470050 | Modulo 4 | 1 |



Polea pivotante
Pivot wheel | Roue pivotante | Polia pivot

| Cod. | Medidas - Dimensions | |
|------|----------------------|---|
| 147 | 120x16 | 2 |



Polea canal "U" 20 mm
U-20 wheel | Galet U-20 | Polia canal U-20

| Cod. | Medidas - Dimensions | | |
|-------------------------------|----------------------|--|-----------------|
| 145 | 60x20 | | 20 |
| 447 | 70x20 | | 20 |
| 124 | 80x20 | | 16 |
| 107 | 90x20 | | 8 |
| 123 | 100x20 | | 8 |
| 108 | 120x20 | | 6 |
| 109 | 150x20 | | 4 |
| 355 | 160x20 | | 4 |
| 117 | 180x20 | | 4 |
| 110 | 200x20 | | 4 |
| Inox Stainless Steel | | | AISI 303 |
| 702 | 60x20 | | 10 |
| 395 | 80x20 | | 6 |
| 396 | 100x20 | | 4 |
| 397 | 120x20 | | 2 |



Polea canal "V" 20 mm
V-20 wheel | Galet V-20 | Polia canal V-20

| Cod. | Medidas - Dimensions | | |
|-------------------------------|----------------------|--|-----------------|
| 446 | 70 V | | 20 |
| 379 | 80 V | | 16 |
| 125 | 90 V | | 8 |
| 128 | 100 V | | 8 |
| 126 | 120 V | | 6 |
| 127 | 150 V | | 4 |
| 3562 | 200 V | | 4 |
| Inox Stainless Steel | | | AISI 303 |
| 144 | 80 V | | 6 |
| 398 | 100 V | | 4 |
| 399 | 120 V | | 2 |
| Canal "V" 10 mm | | | |
| 50230 | 60x10 V | | 30 |



Poleas peso máximo soportado
Maximum loading capacity per wheel
Poids maximum supporté par galet
Peso máximo suportado das polias



Ø > 80 mm

max. 655 kg



Polea canal "U" 20 mm con caja
Wheel with box | Galet en applique | Polia com caixa

| Cod. | Medidas - Dimensions | | |
|-------------------------------|----------------------|--|---------------------|
| 298 | 60x20 | | 12 |
| 300 | 80x20 | | 12 |
| 301 | 90x20 | | 9 |
| 302 | 100x20 | | 8 |
| 303 | 120x20 | | 6 |
| 304 | 150x20 | | 2 |
| 305 | 200x20 | | 4 |
| Inox Stainless Steel | | | AISI 303-304 |
| 670 | 60x20 | | 6 |
| 672 | 80x20 | | 6 |
| 673 | 100x20 | | 4 |
| 674 | 120x20 | | 2 |



Polea canal "V" 20 mm con caja
Wheel with box | Galet en applique | Polia com caixa

| Cod. | Medidas - Dimensions | | |
|-------------------------------|----------------------|--|---------------------|
| 445 | 80 V | | 12 |
| 307 | 90 V | | 9 |
| 308 | 100 V | | 8 |
| 309 | 120 V | | 6 |
| 310 | 150 V | | 2 |
| Inox Stainless Steel | | | AISI 303-304 |
| 675 | 80 V | | 6 |
| 676 | 100 V | | 4 |
| 677 | 120 V | | 2 |
| Canal "V" 10 mm | | | |
| 229 | 60x10 V | | 12 |



Polea canal "U" 20 mm para encastrar
Wheel to fit | Galet à encastrer | Polia de encastrar

| Cod. | Medidas - Dimensions | | |
|-------------------------------|----------------------|--|---------------------|
| 220 | 60x20 | | 12 |
| 159 | 80x20 | | 10 |
| 168 | 90x20 | | 10 |
| 169 | 100x20 | | 8 |
| 170 | 120x20 | | 4 |
| 251 | 150x20 | | 2 |
| Inox Stainless Steel | | | AISI 303-304 |
| 696 | 60x20 | | 6 |
| 678 | 80x20 | | 6 |
| 679 | 100x20 | | 4 |
| 680 | 120x20 | | 2 |



Polea canal "V" 20 mm para encastrar
Wheel to fit | Galet à encastrer | Polia de encastrar

| Cod. | Medidas - Dimensiones | |
|-------------------------------|-----------------------|---------------------|
| 152 | 80 V | 10 |
| 172 | 90 V | 10 |
| 173 | 100 V | 8 |
| 174 | 120 V | 4 |
| 263 | 150 V | 2 |
| Inox Stainless Steel | | AISI 303-304 |
| 681 | 80 V | 6 |
| 682 | 100 V | 4 |
| 683 | 120 V | 2 |
| Canal "V" 10 mm | | |
| 223 | 60x10 V | 12 |



Polea canal "U" 20 mm con soporte
Wheel to weld | Galet à souder | Polia com suporte

| Cod. | Medidas - Dimensiones | |
|-------------------------------|-----------------------|---------------------|
| 588 | 60x20 | 12 |
| 419 | 80x20 | 12 |
| 586 | 80x20 Perfil 60 | 12 |
| 439 | 90x20 | 12 |
| 440 | 100x20 | 10 |
| 441 | 120x20 | 6 |
| 256 | 150x20 | 2 |
| Inox Stainless Steel | | AISI 303-304 |
| 582 | 60x20 | 6 |
| 684 | 80x20 | 4 |
| 685 | 100x20 | 4 |
| 686 | 120x20 | 2 |



Polea canal "V" 20 mm con soporte
Wheel to weld | Galet à souder | Polia com suporte

| Cod. | Medidas - Dimensiones | |
|-------------------------------|-----------------------|---------------------|
| 420 | 80 V | 12 |
| 587 | 80 V Perfil 60 | 12 |
| 442 | 90 V | 12 |
| 443 | 100 V | 10 |
| 444 | 120 V | 6 |
| 265 | 150 V | 2 |
| Inox Stainless Steel | | AISI 303-304 |
| 687 | 80 V | 4 |
| 688 | 100 V | 4 |
| 689 | 120 V | 2 |
| Canal "V" 10 mm | | |
| 574 | 60x10 V | 12 |



Polea canal "U" 16 mm
U-16 Wheel | Galet gorge U-16 | Polia canal U-16

| Cod. | Medidas - Dimensiones | |
|------|-----------------------|----|
| 289 | 50x16 | 30 |
| 279 | 60x16 | 30 |
| 146 | 80x16 | 8 |
| 425 | 90x16 | 8 |
| 426 | 100x16 | 8 |
| 427 | 120x16 | 6 |
| 428 | 150x16 | 4 |



Polea canal "U" 16 mm con caja
Wheel with box | Galet en applique | Polia com caixa

| Cod. | Medidas - Dimensiones | |
|------|-----------------------|----|
| 228 | 60x16 | 12 |
| 421 | 80x16 | 12 |
| 429 | 90x16 | 9 |
| 430 | 100x16 | 8 |
| 431 | 120x16 | 6 |
| 432 | 150x16 | 2 |



Polea canal "U" 16 mm para encastrar
Wheel to fit | Galet à encastrer | Polia de encastrar

| Cod. | Medidas - Dimensiones | |
|------|-----------------------|----|
| 221 | 60x16 | 12 |
| 422 | 80x16 | 10 |
| 433 | 90x16 | 10 |
| 434 | 100x16 | 8 |
| 435 | 120x16 | 4 |
| 266 | 150x16 | 2 |



Polea canal "U" 16 mm con soporte
U-16 Wheel to weld | Galet à souder U-16 | Polia U-16 com suporte

| Cod. | Medidas - Dimensiones | |
|------|-----------------------|----|
| 534 | 60x16 | 12 |
| 423 | 80x16 | 12 |
| 436 | 90x16 | 12 |
| 437 | 100x16 | 10 |
| 438 | 120x16 | 6 |
| 267 | 150x16 | 2 |



Polea nylon canal "U" 20mm | U-20 nylon wheel | Galet nylon U-20 | Polia nylon U-20

| Cod. | Medidas - Dimensiones | |
|-------------------------------|-----------------------|-----------------|
| 388 | 60x20 | 20 |
| 369 | 80x20 | 16 |
| 370 | 90x20 | 8 |
| 371 | 100x20 | 8 |
| 372 | 120x20 | 6 |
| 373 | 150x20 | 4 |
| 3811 | 180x20 | 4 |
| 374 | 200x20 | 4 |
| Inox Stainless Steel | | AISI 303 |
| 742 | 60x20 | 10 |
| 730 | 80x20 | 6 |
| 731 | 90x20 | 4 |
| 732 | 100x20 | 4 |
| 733 | 120x20 | 2 |
| 734 | 150x20 | 2 |
| 735 | 200x20 | 2 |



Polea nylon canal "V" 20 mm | V-20 nylon wheel | Galet nylon V-20 | Polia nylon V-20

| Cod. | Medidas - Dimensiones | |
|-------------------------------|-----------------------|-----------------|
| 380 | 80 V | 16 |
| 375 | 90 V | 8 |
| 376 | 100 V | 8 |
| 377 | 120 V | 6 |
| 378 | 150 V | 4 |
| Inox Stainless Steel | | AISI 303 |
| 736 | 80 V | 4 |
| 737 | 90 V | 4 |
| 738 | 100 V | 4 |
| 739 | 120 V | 2 |
| 740 | 150 V | 2 |



Opciones de suministros de poleas
Wheels' supply options
Fourniture galets
Opções de fornecimento de polias

- Casquillos o tornillo o eje.
- With reducing sleeves or axle or screw.
- Avec bagues de réduction ou axe ou vis.
- Casquilhos o parafuso o eixo.



HERRAJES PUERTAS CORREDERAS A SUELO

BOTTOM SLIDING GATES HARDWARE | FERRURES PORTES COULISSANTES AU SOL | FERRAGENS PORTAS DE CORRER



Polea nylon canal "U" 20 mm con caja
Nylon wheel with box | Galet nylon en applique | Polia nylon com caixa

| Cod. | Medidas - Dimensions | |
|-------------------------------|----------------------|---------------------|
| 227 | 60x20 | 12 |
| 312 | 80x20 | 12 |
| 313 | 90x20 | 9 |
| 314 | 100x20 | 8 |
| 315 | 120x20 | 6 |
| 316 | 150x20 | 2 |
| 317 | 200x20 | 4 |
| Inox Stainless Steel | | AISI 303-304 |
| 703 | 60x20 | 6 |
| 741 | 80x20 | 6 |
| 743 | 100x20 | 4 |
| 744 | 120x20 | 2 |



Polea nylon canal "V" 20 mm con caja
Nylon wheel with box | Galet nylon en applique | Polia nylon com caixa

| Cod. | Medidas - Dimensions | |
|-------------------------------|----------------------|---------------------|
| 311 | 80 V | 12 |
| 318 | 90 V | 9 |
| 319 | 100 V | 8 |
| 320 | 120 V | 6 |
| 321 | 150 V | 2 |
| Inox Stainless Steel | | AISI 303-304 |
| 747 | 80 V | 6 |
| 749 | 100 V | 4 |
| 750 | 120 V | 2 |



Polea nylon canal "U" 20 mm encastrar
Nylon wheel to fit | Galet nylon à encastrer | Polia nylon de encastrar

| Cod. | Medidas - Dimensions | |
|-------------------------------|----------------------|---------------------|
| 224 | 60x20 | 12 |
| 218 | 80x20 | 10 |
| 212 | 90x20 | 10 |
| 213 | 100x20 | 8 |
| 214 | 120x20 | 4 |
| Inox Stainless Steel | | AISI 303-304 |
| 699 | 60x20 | 6 |
| 752 | 80x20 | 6 |
| 753 | 90x20 | 6 |
| 754 | 100x20 | 4 |
| 755 | 120x20 | 2 |



Polea nylon canal "V" 20 mm encastrar
Nylon wheel to fit | Galet nylon à encastrer | Polia nylon de encastrar

| Cod. | Medidas - Dimensions | |
|-------------------------------|----------------------|---------------------|
| 219 | 80 V | 10 |
| 215 | 90 V | 10 |
| 216 | 100 V | 8 |
| 217 | 120 V | 4 |
| Inox Stainless Steel | | AISI 303-304 |
| 756 | 80 V | 6 |
| 757 | 90 V | 6 |
| 758 | 100 V | 4 |
| 759 | 120 V | 2 |



Polea nylon canal "U" 20 mm con soporte
Nylon wheel to weld | Galet nylon à souder | Polia nylon com suporte

| Cod. | Medidas - Dimensions | |
|-------------------------------|----------------------|---------------------|
| 509 | 60x20 | 12 |
| 354 | 80x20 | 12 |
| 382 | 90x20 | 12 |
| 383 | 100x20 | 10 |
| 384 | 120x20 | 6 |
| Inox Stainless Steel | | AISI 303-304 |
| 583 | 60x20 | 6 |
| 760 | 80x20 | 4 |
| 761 | 90x20 | 6 |
| 762 | 100x20 | 4 |
| 763 | 120x20 | 2 |



Polea nylon canal "V" 20 mm soporte
Nylon wheel to weld | Galet nylon à souder | Polia nylon com suporte

| Cod. | Medidas - Dimensions | |
|-------------------------------|----------------------|---------------------|
| 353 | 80 V | 12 |
| 385 | 90 V | 12 |
| 386 | 100 V | 10 |
| 387 | 120 V | 6 |
| Inox Stainless Steel | | AISI 303-304 |
| 764 | 80 V | 4 |
| 765 | 90 V | 6 |
| 766 | 100 V | 4 |
| 767 | 120 V | 2 |

Herrajes correderas pesadas

Heavy duty sliding doors | Portes coulissantes lourdes | Portas corrediças pesadas

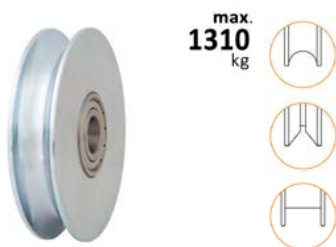

max.
1310
kg



Polea canal 20 mm doble rodamiento
Double bearing wheel | Galet double roulement | Polia dois rolamentos

| Cod. | Medidas - Dimensions | |
|-------|----------------------|---|
| 1081 | 120x20 U | 6 |
| 1092 | 150x20 U | 4 |
| 356 | 200x20 U | 4 |
| 120 | 250x20 U | 3 |
| 121 | 300x20 U | 1 |
| 122 | 320x20 U | 1 |
| 1091 | 150x20 V | 4 |
| 3563 | 200x20 V | 4 |
| 87902 | 200x20 Cuadrada | 4 |



max.
1200
kg



Tandem doble 120 mm
Twin wheels 120 mm | Tandem double 120 mm | Tandem duplo 120 mm

| Cod. | Medidas - Dimensions | |
|------|----------------------|---|
| 871 | 120x20 U | 2 |
| 872 | 120x20 V | 2 |
| 873 | 120x20 Cuadrada | 2 |
| 874 | 120x16 U | 2 |



max.
2000
kg



Tandem doble 200 mm
Twin wheels 200 mm | Tandem double 200 mm | Tandem duplo 200 mm

| Cod. | Medidas - Dimensions | |
|------|----------------------|---|
| 877 | 200x20 U | 1 |
| 878 | 200x20 V | 1 |
| 879 | 200x20 Cuadrada | 1 |



Cerradura de gancho 30 mm
Hook lock | Serrure à crochet | Fechadura gancho

| Cod. | Para For Pour | |
|------|---------------------------------------|---|
| 424 | Cilindro 55 mm latón centrado | 1 |
| 4240 | S/cilindro No cylinder S/cylindre | 1 |



Cerradura de gancho 50 mm
Hook lock | Serrure à crochet | Fechadura gancho

| Cod. | Para For Pour | |
|------|---------------------------------------|---|
| 322 | Cilindro 55 mm latón centrado | 1 |
| 3220 | S/cilindro No cylinder S/cylindre | 1 |



Cerradura de gancho 60 mm
Hook lock | Serrure à crochet | Fechadura gancho

| Cod. | Para For Pour | |
|------|---------------------------------------|---|
| 325 | Cilindro 55 mm latón centrado | 1 |
| 3250 | S/cilindro No cylinder S/cylindre | 1 |



Caja para cerraduras
Cover box | Couverture serrure | Caixa fechadura

| Cod. | Perfil Profile Profil | |
|------|---------------------------|----|
| 326 | 40 mm | 10 |
| 327 | 50 mm | 10 |



Tirador
Puller | Poignée à encastrar | Puxador

| Cod. | Medidas - Dimensions | |
|------|----------------------|----|
| 576 | 175x76 Mediano | 10 |
| 577 | 200x90 Grande | 10 |

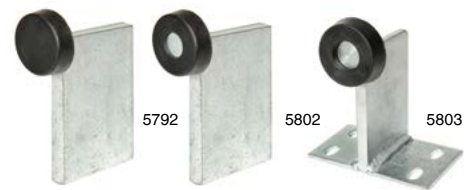

Tope puerta corredera
Stopper | Arrêt | Topo

| Cod. | Medidas - Dimensions | |
|------|----------------------|----|
| 5792 | 50x85 | 10 |
| 5802 | 70x130 | 12 |
| 5803 | 70x130 | 2 |

Poleas 60 mm anti-atrapamiento y anti-descarrilamiento

Anti-pinch and anti-derailment wheels | Galets anti-pincement et anti-déraillement | Anti-aprisionamento e anti-descarrilamento

Características

Characteristic | Caractéristique | Características

ES

- Poleas en acero inoxidable y acero cincado.
- Chapa de aluminio en bruto o lacada.
- Mayor resistencia a la corrosión: tornillería con tratamiento anti-corrosión (Geomet®) para una buena compatibilidad con el aluminio.
- Peso máximo por unidad: 300 kg.
- Cincado de grado 3.
- Perfil mín para encastrar las poleas: 30 mm.

EN

- Wheels in Steel and Stainless Steel
- Rough and Laquered Aluminium Plate
- Anti-corrosion (Geomet) treatment on screws: better resistance of the wheel.
- Max. loading capacity : 300 kg each.
- Grade III Zinc plated.
- Min. Profile width to fit the wheels in: 30 mm.

FR

- Galets en Acier ou Inox.
- Platine Aluminium brute ou laquée.
- Traitement anti-corrosion (Geomet) sur visserie: plus grande résistance du galet.
- Capacité max. par roue : 300kg.
- Zingage de Niveau III.
- Largeur Min. du profil où le galet doit s'encaster : 30mm.

Para puertas

For doors | Pour les portes | Para portas



Compatibles con

For | Compatible avec | Compatível com

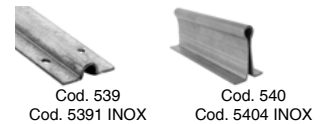

Polea caja aluminio 60x16 mm
Aluminum box | Support en aluminium | Caixa alumínio

| Cod. | Acabado Finish Finition Acabamento | |
|-------------------------------|---|-----------------|
| 36016 | Aluminio Aluminum | 2 |
| 36016/1 | Blanco White Blanc | 2 |
| 36016/2 | Negro Black Noir | 2 |
| Inox Stainless Steel | | AISI 303 |
| 36016PI | Aluminio Aluminum | 2 |
| 36016/1PI | Blanco White Blanc | 2 |
| 36016/2PI | Negro Black Noir | 2 |



Polea semi-encastar caja aluminio 60x16 mm
Semi recessed wheel | Galet semi-encastée | Polia semi-encastar

| Cod. | Acabado Finish Finition Acabamento | |
|-------------------------------|---|-----------------|
| 26016 | Aluminio Aluminum | 2 |
| 26016/1 | Blanco White Blanc | 2 |
| 26016/2 | Negro Black Noir | 2 |
| Inox Stainless Steel | | AISI 303 |
| 26016PI | Aluminio Aluminum | 2 |
| 26016/1PI | Blanco White Blanc | 2 |
| 26016/2PI | Negro Black Noir | 2 |



Polea encastrar caja aluminio 60x16 mm
Aluminum box to recess | Galet à encastrar | Caixa alumínio

| Cod. | Acabado Finish Finition Acabamento | |
|-------------------------------|---|-----------------|
| 16016 | Aluminio Aluminum | 2 |
| 16016/1 | Blanco White Blanc | 2 |
| 16016/2 | Negro Black Noir | 2 |
| Inox Stainless Steel | | AISI 303 |
| 16016PI | Aluminio Aluminum | 2 |
| 16016/1PI | Blanco White Blanc | 2 |
| 16016/2PI | Negro Black Noir | 2 |

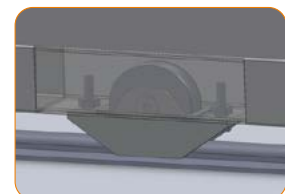
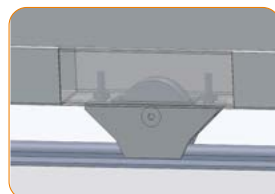
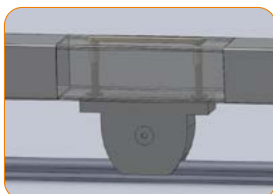



Herrajes Puertas Autoportantes

Cantilever Gates Hardware

Ferrures pour Portes Autoportantes

Ferragens Portas Autoportantes



Carros autoportantes
Rail autoportante
Tope encuentro
Rueda encuentro
Soporte tope encuentro
Kit varillas de fijación
Chapas de regulación
Cajas de poleas guía
Tope puertas correderas



Cantilever wheel carriages
Cantilever track
End stop
End wheel support
End stopper support
Fastening pins
Regulation plates
Adjustable guide brackets
Stoppers



Montures autoportante avec roulement
Rail pour portes autoportantes
Arrêt
Galet de guidage
Support d'arrêt
Tiges de fixation
Plaques de régulation
Plaques guide
Arrêts



Carros autoportante axial
Calha para autoportante
Topo de encontro
Roda de encontro
Suporte topo de encontro
Varões de fixação
Chapas de regulação
Caixas regulável
Topos



STEEL
ACIER
AÇO

DIMENSIONES

DIMENSIONS | DIMENSION | DIMENSÕES

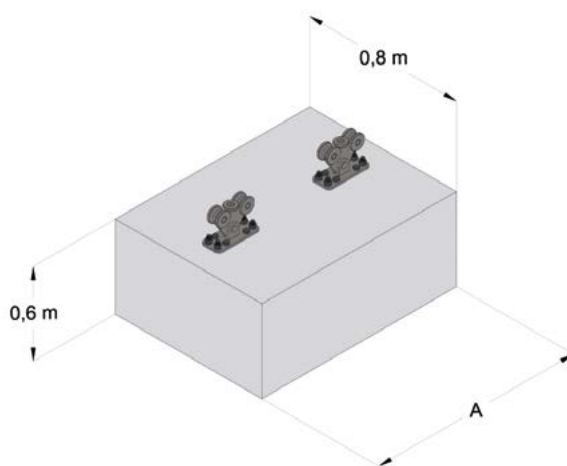
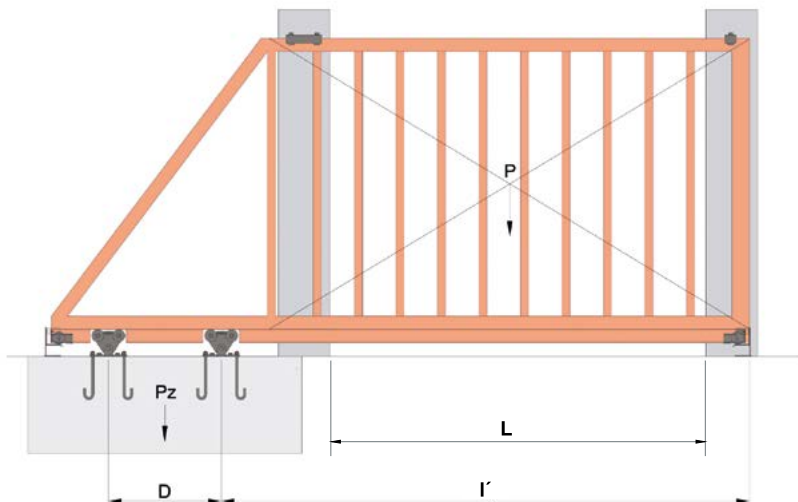

ES

P= Peso de la puerta con el rail incluido.
L= Luz de paso (Apertura para permitir el paso).
I'= Distancia entre el carro interior a tope final de puerta.
D= Distancia entre los centros de los dos carros autoportantes.
A= Longitud de la zapata.
Pz= Peso mínimo de la cimentación para compensar el esfuerzo de carga que sufren los carros (Evitar que pudiera levantar la cimentación).

EN

P= Weight of the gate including the track
L= Gate opening.
I'= Distance between the inner carriage and gate end stop.
D= Distance between the centres of the two cantilever wheel carriage.
A= Counter.
Pz= Minimum weight of the foundation to compensate the load stress suffered by the carriage (to prevent the foundation from being lifted).

FR

P= Poids de la porte, rail compris.
L= Longueur entre poteaux (ouverture pour permettre le passage).
I'= Distance entre la monture intérieure et la butée de la porte.
D= Distance entre les centres des deux montures autoportantes.
A= Longueur que autoportante.
Pz= Poids minimum de la fondation pour compenser les contraintes de charge subies par les chariots. La contrainte de charge subie par les montures (pour éviter un possible soulèvement de la fondation).

PO

P= Peso da porta, incluindo a trilha.
L= Abertura entre postes.
I'= Distância entre o carro interior e o batente da porta.
D= Distância entre os centros dos dois carros autoportantes.
A= Comprimento da sapata.
Pz= Peso mínimo da fundação para compensar o esforço de carga sofrida pelos carros (para evitar que a fundação seja levantada).

Gama M Simple E150

| Peso Puerta (kg) | L=2 m | | L=2,5 m | | L=3 m | | L=3,5 m | | L=4 m | |
|------------------|-------|-----|---------|-----|-------|-----|---------|-----|-------|-----|
| | D | A | D | A | D | A | D | A | D | A |
| 50 | 0,2 | 0,8 | 0,3 | 0,9 | 0,3 | 0,9 | 0,4 | 1,0 | 0,4 | 1 |
| 100 | 0,5 | 1,1 | 0,7 | 1,3 | 0,8 | 1,4 | 0,9 | 1,5 | 1 | 1,6 |
| 150 | 1 | 1,6 | 1,3 | 1,9 | 1,5 | 2,1 | 1,8 | 2,4 | 2,0 | 2,6 |

Gama M Doble E300

| Peso Puerta (kg) | L=2 m | | L=2,5 m | | L=3 m | | L=3,5 m | | L=4 m | | L=4,5 m | | L=5 m | | L=5,5 m | | L=6 m | |
|------------------|-------|-----|---------|-----|-------|-----|---------|-----|-------|-----|---------|-----|-------|-----|---------|-----|-------|-----|
| | D | A | D | A | D | A | D | A | D | A | D | A | D | A | D | A | D | A |
| 50 | 0,1 | 1,1 | 0,2 | 0,8 | 0,2 | 0,8 | 0,2 | 1 | 0,2 | 1,1 | 0,3 | 0,9 | 0,3 | 0,9 | 0,3 | 1 | 0,3 | 1,1 |
| 100 | 0,2 | 1,1 | 0,3 | 0,9 | 0,3 | 1,1 | 0,4 | 1,1 | 0,4 | 1,1 | 0,5 | 1,1 | 0,5 | 1,1 | 0,6 | 1,2 | 0,6 | 1,2 |
| 150 | 0,4 | 1,1 | 0,5 | 1,1 | 0,5 | 1,1 | 0,6 | 1,2 | 0,7 | 1,3 | 0,8 | 1,4 | 0,9 | 1,5 | 1 | 1,6 | 1 | 1,6 |
| 200 | 0,5 | 1,1 | 0,7 | 1,3 | 0,8 | 1,4 | 0,9 | 1,5 | 1 | 1,6 | 1,2 | 1,8 | 1,3 | 1,9 | 1,4 | 2 | 1,5 | 2,1 |
| 250 | 0,8 | 1,4 | 0,9 | 1,5 | 1,1 | 1,7 | 1,3 | 1,9 | 1,5 | 2,1 | 1,7 | 2,3 | 1,8 | 2,4 | 2 | 2,6 | 2,2 | 2,8 |
| 300 | 1 | 1,6 | 1,3 | 1,9 | 1,5 | 2,1 | 1,8 | 2,4 | 2 | 2,6 | 2,3 | 2,9 | 2,5 | 3,1 | 2,8 | 3,4 | 3 | 3,6 |

Gama L Simple E500

| Peso Puerta (kg) | L=2 m | | L=2,5 m | | L=3 m | | L=3,5 m | | L=4 m | | L=4,5 m | | L=5 m | | L=5,5 m | | L=6 m | |
|------------------|-------|-----|---------|-----|-------|-----|---------|-----|-------|-----|---------|-----|-------|-----|---------|-----|-------|-----|
| | D | A | D | A | D | A | D | A | D | A | D | A | D | A | D | A | D | A |
| 100 | 0,2 | 1,1 | 0,2 | 1,4 | 0,2 | 1,6 | 0,3 | 1,3 | 0,3 | 1,4 | 0,3 | 1,6 | 0,4 | 1,4 | 0,4 | 1,6 | 0,4 | 1,6 |
| 150 | 0,2 | 1,6 | 0,3 | 1,4 | 0,3 | 1,6 | 0,4 | 1,4 | 0,4 | 1,6 | 0,5 | 1,5 | 0,5 | 1,6 | 0,6 | 1,6 | 0,6 | 1,6 |
| 200 | 0,3 | 1,4 | 0,4 | 1,4 | 0,5 | 1,3 | 0,5 | 1,5 | 0,6 | 1,4 | 0,7 | 1,4 | 0,8 | 1,2 | 0,9 | 1,3 | 0,9 | 1,3 |
| 250 | 0,4 | 1,4 | 0,5 | 1,4 | 0,6 | 1,4 | 0,7 | 1,4 | 0,8 | 1,2 | 0,9 | 1,3 | 1 | 1,4 | 1,2 | 1,6 | 1,2 | 1,6 |
| 300 | 0,5 | 1,3 | 0,7 | 1,3 | 0,8 | 1,2 | 0,9 | 1,3 | 1 | 1,4 | 1,2 | 1,6 | 1,3 | 1,7 | 1,5 | 1,9 | 1,5 | 1,9 |
| 350 | 0,7 | 1,3 | 0,8 | 1,2 | 1 | 1,4 | 1,2 | 1,6 | 1,3 | 1,7 | 1,5 | 1,9 | 1,6 | 2 | 2 | 2,2 | 2 | 2,2 |
| 400 | 0,8 | 1,2 | 1 | 1,4 | 1,2 | 1,6 | 1,4 | 1,8 | 1,6 | 2 | 1,8 | 2,2 | 2 | 2,4 | 2,4 | 2,8 | 2,4 | 2,8 |
| 450 | 1 | 1,4 | 1,3 | 1,7 | 1,5 | 1,9 | 1,8 | 2,2 | 2 | 2,4 | 2,3 | 2,7 | 2,5 | 2,9 | 3 | 3,2 | 3 | 3,2 |
| 500 | 1,3 | 1,7 | 1,6 | 2 | 1,9 | 2,3 | 2,2 | 2,6 | | | | | | | | | | |

Gama L Doble E700

| Peso Puerta (kg) | L=2 m | | L=2,5 m | | L=3 m | | L=3,5 m | | L=4 m | | L=4,5 m | | L=5 m | | L=5,5 m | | L=6 m | |
|------------------|-------|-----|---------|-----|-------|-----|---------|-----|-------|-----|---------|-----|-------|-----|---------|-----|-------|-----|
| | D | A | D | A | D | A | D | A | D | A | D | A | D | A | D | A | D | A |
| 100 | 0,1 | 2,1 | 0,2 | 1,4 | 0,2 | 1,6 | 0,2 | 1,9 | 0,2 | 2,1 | 0,3 | 1,6 | 0,3 | 1,8 | 0,3 | 2 | 0,3 | 2,1 |
| 150 | 0,2 | 1,6 | 0,2 | 2 | 0,3 | 1,6 | 0,3 | 1,9 | 0,3 | 2,1 | 0,4 | 1,8 | 0,4 | 2 | 0,4 | 2,2 | 0,5 | 1,9 |
| 200 | 0,2 | 2,1 | 0,3 | 1,8 | 0,3 | 2,1 | 0,4 | 1,9 | 0,4 | 2,1 | 0,5 | 1,9 | 0,5 | 2,1 | 0,6 | 2 | 0,6 | 2,1 |
| 250 | 0,3 | 1,8 | 0,4 | 1,8 | 0,4 | 2 | 0,5 | 1,9 | 0,6 | 1,8 | 0,6 | 2 | 0,7 | 1,9 | 0,8 | 1,8 | 0,8 | 2 |
| 300 | 0,4 | 1,6 | 0,5 | 1,6 | 0,5 | 1,9 | 0,6 | 1,9 | 0,7 | 1,8 | 0,8 | 1,8 | 0,9 | 1,8 | 1 | 1,8 | 1 | 1,9 |
| 350 | 0,5 | 1,5 | 0,6 | 1,6 | 0,7 | 1,6 | 0,8 | 1,6 | 0,9 | 1,7 | 1 | 1,7 | 1,1 | 1,7 | 1,2 | 1,8 | 1,3 | 1,9 |
| 400 | 0,5 | 1,7 | 0,7 | 1,5 | 0,8 | 1,6 | 0,9 | 1,7 | 1 | 1,7 | 1,2 | 1,8 | 1,3 | 1,9 | 1,4 | 2 | 1,5 | 2,1 |
| 450 | 0,6 | 1,6 | 0,8 | 1,5 | 0,9 | 1,6 | 1,1 | 1,7 | 1,2 | 1,8 | 1,4 | 2 | 1,5 | 2,1 | 1,7 | 2,3 | 1,8 | 2,4 |
| 500 | 0,8 | 1,4 | 0,9 | 1,5 | 1,1 | 1,5 | 1,3 | 1,9 | 1,5 | 2,1 | 1,7 | 2,3 | 1,8 | 2,4 | 2 | 2,6 | 2,2 | 2,8 |
| 550 | 0,9 | 1,5 | 1,1 | 1,7 | 1,3 | 1,9 | 1,5 | 2,1 | 1,7 | 2,3 | 2 | 2,6 | 2,2 | 2,8 | 2,4 | 3 | 2,6 | 3,2 |
| 600 | 1 | 1,6 | 1,3 | 1,9 | 1,5 | 2,1 | 1,8 | 2,4 | 2 | 2,6 | 2,3 | 2,9 | 2,5 | 3,1 | 2,8 | 3,4 | 3 | 3,6 |
| 650 | 1,2 | 1,8 | 1,5 | 2,1 | 1,8 | 2,4 | 2,1 | 2,7 | 2,4 | 3 | 2,7 | 3,3 | | | | | | |
| 700 | 1,4 | 2 | 1,8 | 2,4 | 2,1 | 2,7 | | | | | | | | | | | | |



HERRAJES PUERTAS AUTOPORTANTES

CANTILEVER GATES HARDWARE | FERRURES POUR PORTES AUTOPORTANTES | FERRAGENS PORTAS AUTOPORTANTES

ES

Dos rangos de herrajes en función del peso de la puerta:

- Gama M - 300 Kg
- Gama L - 700 Kg

Para otros pesos y dimensiones consulte con nosotros.

Buscaremos la solución óptima a sus necesidades.

EN

Two ranges of fittings depending on the weight of the door:

- M Range - 300 Kg
- L Range - 700 Kg

For other weights and dimensions consult us.

We will find the optimal solution to your needs.

FR

Deux gammes de ferrures en fonction du poids de la porte:

- Gamme M - 300 Kg
- Gamme L - 700 Kg

Pour d'autres poids et dimensions nous consulter.

Nous trouverons la solution optimale à vos besoins.

PO

Duas gamas de ferragens em função do peso da porta:

- Gama M - 300 Kg
- Gama L - 700 Kg

Para outros pesos e dimensões consulte-nos.

Encontraremos a solução ideal para as suas necessidades.

Gama M | U-60

E150-300

M Range | Gamme M | Gama M



Carro autoportante axial simple

5 Cantilever wheel carriage with axial bearing
Monture autoportante avec roulement à billes simple
Carro autoportante axial simple

| Cod. | Medidas - Dimensions | |
|------|----------------------|---|
| 941 | Gama M Simple | 2 |



Carro autoportante axial doble

9 Cantilever wheel carriage with axial bearing
Monture autoportante avec roulement à billes double
Carro autoportante axial duplo

| Cod. | Medidas - Dimensions | |
|------|---------------------------------|---|
| 942 | Gama M Doble Double Duplo | 2 |



Rail autoportante U-60

U-60 cantilever track | Rail supérieur U-60 | Calha para autoportante U-60

| Cod. | Medidas - Dimensions | | |
|------|----------------------|-----|-----|
| 479 | U-60 | 3 m | ±1% |



Tope encuentro

End stop | Arrêt | Topo de encontro

| Cod. | Medidas - Dimensions | |
|------|----------------------------|---|
| 943 | Gama M M Range Gamme M | 2 |



Rueda encuentro

End wheel support | Galet de guidage | Roda de encontro

| Cod. | Medidas - Dimensions | |
|------|----------------------------|---|
| 9431 | Gama M M Range Gamme M | 2 |



Soporte fin Encuentro

End wheel support | Galet de guidage | Roda de encontro

| Cod. | Medidas - Dimensions | |
|------|----------------------------|---|
| 9432 | Gama M M Range Gamme M | 2 |

Accesorios

Accessories | Accessoires | Acessórios



Soporte tope encuentro

End stopper support | Support d'arrêt | Suporte topo de encontro

| Cod. | Medidas - Dimensions | |
|------|----------------------------|---|
| 9430 | Gama M M Range Gamme M | 2 |



Caja de poleas guía simple regulable

Adjustable guide bracket | Plaque guide | Caixa regulável

| Cod. | Medidas - Dimensions | |
|-------------------------------|----------------------|-----------------------|
| 161 | Ø 30 6-94 | 12 |
| 1614 | Ø 35 11-89 | 12 |
| Inox Stainless Steel | | AISI 303 - 304 |
| 306 | Ø 30 6-94 | 4 |



Caja de poleas regulable

Adjustable guide bracket | Plaque guide | Caixa regulável

| Cod. | Medidas - Dimensions | |
|-------------------------------|----------------------|-----------------------|
| 167 | Ø 30 30-65 | 6 |
| 1675 | Ø 35 25-60 | 6 |
| 171 | Ø 40 58-92 | 6 |
| Inox Stainless Steel | | AISI 303 - 304 |
| 358 | Ø 30 30-65 | 4 |
| 359 | Ø 40 58-92 | 1 |

Gama L | U-70

L Range | Gamme L | Gama L



Carro autoportante axial simple
5 Cantilever wheel carriage with axial bearing
Monture autoportante avec roulement à billes simple
Carro autoportante axial simple

| Cod. | Medidas - Dimensions | |
|------|----------------------|---|
| 861 | Gama L Simple | 2 |



Carro autoportante axial doble
10 Cantilever wheel carriage with axial bearing
Monture autoportante avec roulement à billes double
Carro autoportante axial duplo

| Cod. | Medidas - Dimensions | |
|------|---------------------------------|---|
| 862 | Gama L Doble Double Duplo | 1 |



Rail autoportante U-70
U-70 cantilever track | Rail supérieur U-70 |
Calha para autoportante U-70

| Cod. | Medidas - Dimensions | |
|------|----------------------|-----|
| 470 | U-70 | 3 m |



Tope encuentro
End stop | Arrêt | Topo de encontro

| Cod. | Medidas - Dimensions | |
|------|----------------------------|---|
| 863 | Gama L L Range Gamme L | 2 |



Rueda encuentro
End wheel support | Galet de guidage | Roda de encontro

| Cod. | Medidas - Dimensions | |
|------|----------------------------|---|
| 8631 | Gama L L Range Gamme L | 2 |



Soporte tope encuentro
End stopper support | Support d'arrêt |
Suporte topo de encontro

| Cod. | Medidas - Dimensions | |
|------|----------------------------|---|
| 8630 | Gama L L Range Gamme L | 2 |



Kit varilla recta fijación
Fastening pin | Tige de fixation | Varão de fixação

| Cod. | Kit | Para For Pour | |
|------|-----------|-------------------|-------|
| 8602 | Kit= 4 Ud | 8610C y 8620C | 1 Kit |



Kit varilla curva fijación
Curved fastening pin | Tige de fixation courbée |
Varão de fixação curva

| Cod. | Kit | Para For Pour | |
|------|-----------|-------------------|-------|
| 8622 | Kit= 4 Ud | 8610C y 8620C | 1 Kit |



Chapa regulación
Regulation plate | Plaque de régulation |
Chapa de regulação

| Cod. | Medidas - Dimensions | |
|-------|----------------------|---|
| 8610C | Simple | 2 |
| 8620C | Doble | 2 |

Accesorios válidos para Gamas Autoportantes M y L
Accessories valid for M and L Cantilever Doors Ranges
Accessoires valables pour les Gammes M et L pour Portes Autoportantes
Acessórios válidos para as Gamas Autoportantes M e L



Cajas de poleas guía regulable a pared
Wall mounted guide bracket | Plaques guide |
Caixas reguláveis

| Cod. | Medidas - Dimensions | |
|------|----------------------|---|
| 1612 | Ø 40 20-100 | 2 |
| 1673 | Ø 40 20-76 | 4 |

Inox | Stainless Steel **AISI 303 - 304**

| | | |
|-------|-------------|---|
| 16121 | Ø 40 20-100 | 2 |
| 16730 | Ø 40 20-76 | 4 |



5792



5802

Tope puerta corredera
Stopper | Arrêt | Topo

| Cod. | Medidas - Dimensions | |
|------|----------------------|----|
| 5792 | 50x85 | 10 |
| 5802 | 70x130 | 12 |



Tope puerta corredera atornillar
Stopper to screw | Arrêt à visser | Topo parafusar

| Cod. | Medidas - Dimensions | |
|------|----------------------|---|
| 5803 | 70x130 | 2 |



Herrajes Puertas Correderas Colgadas
Hanging Sliding Gates Hardware
Ferrures pour Portes Coulissantes Suspendues
Ferragens Portas Corrediças Suspensas



Gama U-30
Gama U-40
Gama U-60
Accesorios
Gama U-70



U-30 Range
U-40 Range
U-60 Range
Accessories
U-70 Range



Gamme U-30
Gamme U-40
Gamme U-60
Accessoires
Gamme U-70



Gama U-30
Gama U-40
Gama U-60
Accessórios
Gama U-70

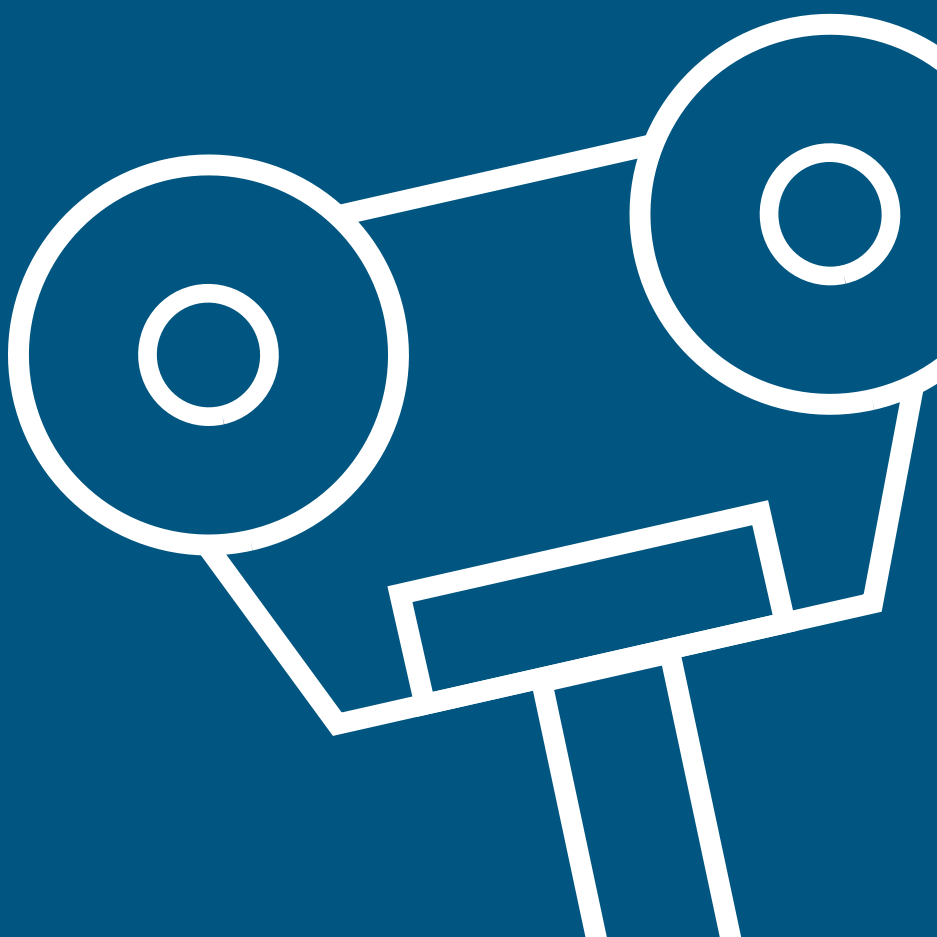

ALUMINIUM
ALUMINUM
ALUMÍNIO



STAINLESS
STEEL



STEEL
ACIER
AÇO



WOOD
BOIS
MADEIRA

A
LUMINIO
ALUMINIUM
ALUMINIO

I
NOX
STAINLESS
STEEL

A
CERO
STEEL
ACIER
AÇO

M
ADERA
WOOD
BOIS
MADEIRA



Puertas correderas colgadas

Hanging sliding doors

Portes coulissantes suspendues

Portas corrediças suspensas

| | | |
|----------------------------------|----------|------|
| Hasta Up to Jusqu'à Até | 60 kg | U-30 |
| | 75 kg | U-30 |
| | 150 kg | U-40 |
| | 300 kg | U-40 |
| | 450 kg | U-60 |
| | 1.200 kg | U-70 |
| | 2.000 kg | U-70 |

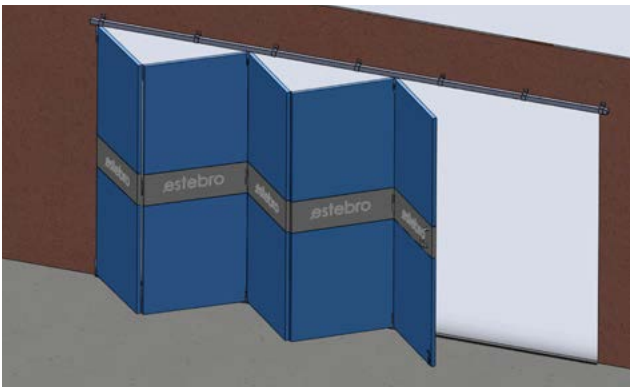

Puertas correderas plegables solapadas

Folding doors with overlapping panels

Portes coulissantes pliables à panneaux superposés

Portas corrediças drobráveis com lapela

| | | |
|----------------------------------|--------|------|
| Hasta Up to Jusqu'à Até | 50 kg | U-40 |
| | 100 kg | U-60 |



Puertas articuladas en curva

Sliding curved doors

Portes coulissantes en courbe

Portas articuladas em curva

| | | |
|----------------------------------|--------|------|
| Hasta Up to Jusqu'à Até | 75 kg | U-40 |
| | 150 kg | U-40 |
| | 200 kg | U-60 |

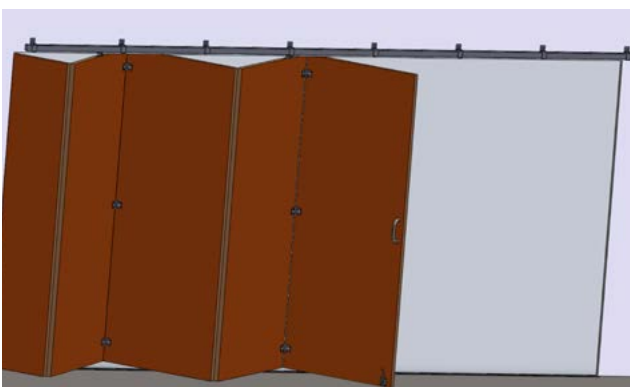

Puertas correderas de acordeón

Accordion doors

Portes coulissantes en accordéon

Portas de acordeão

| | | |
|----------------------------------|--------|------|
| Hasta Up to Jusqu'à Até | 50 kg | U-40 |
| | 100 kg | U-60 |



Gama U-30

E60 - E75

U-30 Range | Gamme U-30



Kit puerta corredera hasta 60 kg
Up to 60 kg | Jusqu'à 60 kg | Até 60 kg

| Cod. | Medidas - Dimensions | |
|------|----------------------|-------|
| KC60 | 60 kg | 1 set |



Kit puerta corredera hasta 60 kg - NYLON
Nylon Up to 60 kg | Jusqu'à 60 kg | Até 60 kg

| Cod. | Medidas - Dimensions | |
|-------|----------------------|-------|
| KC60N | 60 kg | 1 set |



Kit puerta corredera hasta 75 kg
Up to 75 kg | Jusqu'à 75 kg | Até 60 kg

| Cod. | Medidas - Dimensions | |
|-------|----------------------|-------|
| KC75N | 75 kg | 1 set |



A
LUMINIO
ALUMINIUM
ALUMINIUM
ALUMÍNIO

Raíl superior aluminio U-30 pestaña
U-30 Aluminum top track with edge
Raíl supérieur en aluminium U-30 à rebords
Trilho superior alumínio U-30 pestana

| Cod. | Medidas - Dimensions | | |
|------|----------------------|-----|-----|
| 5752 | U-30 Punzonado | 2 m | ±1% |
| 5751 | U-30 Punzonado | 3 m | |



A
LUMINIO
ALUMINIUM
ALUMINIUM
ALUMÍNIO

Abrazadera raíl aluminio U-30 pestaña
U-30 Aluminum top track bracket with edges
Équerre pour raíl en aluminium U-30 à rebords
Esquadro trilho alumínio U-30 pestana

| Cod. | Medidas - Dimensions | |
|-------|----------------------|----|
| 57520 | U-30 | 10 |



A
LUMINIO
ALUMINIUM
ALUMINIUM
ALUMÍNIO

Tapa embellecedor raíl aluminio U-30 pestaña
U-30 Aluminum top track escutcheon cap with edge
Cache embellissant raíl aluminium U-30 à rebords
Tampa embellecedora trilho alumínio U-30 pestana

| Cod. | Medidas - Dimensions | |
|--------|----------------------|-----|
| 575152 | U-30 | 2 m |
| 575151 | U-30 | 3 m |



A
LUMINIO
ALUMINIUM
ALUMINIUM
ALUMÍNIO

Juego embellecedor para tapa embellecedor
End cap kit for aluminum escutcheon cap
Jeu d'embouts pour cache en aluminium
Jogo decorativo tapa em alumínio

| Cod. | Medidas - Dimensions | |
|--------|-----------------------|-------|
| 57515T | Dcha+Izq Right+Left | 1 set |



Vídeo



A
LUMINIO
ALUMINIUM
ALUMINIUM
ALUMÍNIO

Raíl superior aluminio U-30 simple
U-30 Aluminum simple top track
Raíl supérieur en aluminium U-30 simple
Trilho superior alumínio U-30 simple

| Cod. | Medidas - Dimensions | | |
|------|----------------------|-----|--|
| 5592 | U-30 Punzonado | 2 m | |
| 5591 | U-30 Punzonado | 3 m | |



A
LUMINIO
ALUMINIUM
ALUMINIUM
ALUMÍNIO

Curva superior aluminio U-30 simple
U-30 Aluminum simple top bend
Courbe supérieure aluminium simple
Curva alumínio superior simple

| Cod. | Medidas - Dimensions | |
|-------|----------------------|---|
| 55913 | U-30 | 1 |



A
LUMINIO
ALUMINIUM
ALUMINIUM
ALUMÍNIO

Escuadra para soporte raíl aluminio U-30 simple
U-30 Aluminum simple bracket
Équerre pour raíl en aluminium U-30 simple
Esquadro trilho alumínio U-30 simple

| Cod. | Medidas - Dimensions | |
|-------|----------------------|----|
| 57525 | U-30 | 20 |

Gama U-30

U-30 Range | Gamme U-30



Rail superior U-30
U-30 Top track | Rail supérieur | Trilho superior

| Cod. | Medidas - Dimensions | ±1% |
|-------------------------------|----------------------|-----------------|
| 473 | U-30 Punzonado | 3 m |
| 4732 | U-30 Punzonado | 2 m |
| Inox Stainless Steel | | AISI 316 |
| 4760 | U-30 INOX | 3 m |

Consultar rail U-30 sin punzonar



Curva superior U-30
Top bend | Courbe supérieure | Curva superior

| Cod. | Medidas - Dimensions | |
|-------------------------------|----------------------|-----------------|
| 4735 | U-30 | 1 |
| Inox Stainless Steel | | AISI 316 |
| 47351 | U-30 INOX | 1 |



Tope rail U-30
Top track stopper for rails | Butée rail | Topo guia

| Cod. | Para For Pour | |
|-------------------------------|-------------------|-----------------|
| 47301 | U-30 | 10 |
| Inox Stainless Steel | | AISI 316 |
| 47312 | U-30 INOX | 10 |



Rollapar doble U-30 E60
U-30 Double trolley | Monture à galets double U-30 | Rodízio U-30 duplo

| Cod. | Medidas - Dimensions | |
|------|----------------------------------|----|
| 459 | U-30 Acero Steel Acier Aço | 12 |
| 459N | U-30 Nylon | 12 |



Rollapar doble desmontable U-30 nylon E75
U-30 Double trolley nylon | Monture à galets double U-30 nylon | Rodízio U-30 duplo nylon

| Cod. | Medidas - Dimensions | |
|-------------------------------|----------------------|-----------------|
| 4640 | U-30 Nylon | 12 |
| Inox Stainless Steel | | AISI 316 |
| 4641 | U-30 INOX | 12 |



NEW
NUEVO

Rollapar colgadero simple U-30
U-30 Simple trolley | Monture simple U-30 fixation sur plat | Rodízio pendurado simple U-30

| Cod. | Medidas - Dimensions | |
|-------|----------------------|----|
| 30591 | U-30 Nylon | 50 |



Rollapar simple U-30 gancho
Hook trolley | Monture à crochet | Rodízio com gancho

| Cod. | Para For Pour | |
|------|-------------------|----|
| 4635 | U-30 | 60 |



Set adaptador a madera para rollapar
Hanging plates set | Set adaptateur à bois | Set de adaptação a madeira

| Cod. | Para For Pour | |
|-------------------------------|-------------------|-----------------|
| 4590 | U-30 | 25 |
| Inox Stainless Steel | | AISI 316 |
| 459010 | U-30 | 25 |



Abrazadera para rail U-30
U-30 Top track bracket | Support rail | Suporte rail

| Cod. | Para For Pour | |
|-------------------------------|-------------------|-----------------|
| 4591 | U-30 | 8 |
| Inox Stainless Steel | | AISI 316 |
| 45911 | U-30 | 8 |



Empalme para rail U-30
U-30 Joining bracket | Joint pour rail U-30 | Conexão para trilho U-30

| Cod. | Para For Pour | |
|-------------------------------|-------------------|-----------------|
| 47310 | U-30 | 4 |
| Inox Stainless Steel | | AISI 316 |
| 47311 | U-30 INOX | 4 |



Guiador a suelo de plástico
Plastic floor guide | Guide à sol en plastique | Guia solo plastico

| Cod. | Medidas - Dimensions | |
|------|----------------------|----|
| 5006 | 46,5x15 | 10 |



Curva inferior U-19 para U-30
Bottom bend | Courbe inférieure | Curva inferior

| Cod. | Para For Pour | |
|-------------------------------|--------------------------|-----------------|
| 4812 | U-19 para rail U-30 | 1 |
| Inox Stainless Steel | | AISI 316 |
| 48120 | U-19 para Rail U-30 INOX | 1 |



Gama U-40

E150 - E300

U-40 Range | Gamme U-40



Kit puerta corredera hasta 150 kg
Up to 150 kg | Jusqu'à 150 kg | Até 150 kg

| Cod. | Medidas - Dimensions | |
|-------|----------------------|-------|
| KC150 | 150 kg | 1 set |



Kit puerta corredera hasta 300 kg
Up to 300 kg | Jusqu'à 300 kg | Até 300 kg

| Cod. | Medidas - Dimensions | |
|-------|----------------------|-------|
| KC300 | 300 kg | 1 set |



Video



Rail superior U-40
U-40 Top track | Rail supérieur | Trilho superior

| Cod. | Medidas - Dimensions | | $\pm 1\%$ |
|-------------------------------|----------------------|-----------------|-----------|
| 478 | U-40 | 3 m | |
| Inox Stainless Steel | | AISI 316 | |
| 472 | U-40 INOX | 3 m | |



Curva superior U-40
Top bend | Courbe supérieure | Curva superior

| Cod. | Medidas - Dimensions | |
|-------------------------------|----------------------|-----------------|
| 477 | U-40 | 1 |
| Inox Stainless Steel | | AISI 316 |
| 4771 | U-40 INOX | 1 |



Tope rail U-40
Top track stopper for rails | Butée rail | Topo guia

| Cod. | Para For Pour | |
|-------------------------------|-------------------|-----------------|
| 47801 | U-40 | 10 |
| Inox Stainless Steel | | AISI 316 |
| 47812 | U-40 INOX | 10 |



Rollapar simple U-40 E150
U-40 Simple trolley | Monture à galets simple U-40 | Rodizio simple U-40

| Cod. | Medidas - Dimensions | |
|-------------------------------|-------------------------|-----------------|
| 461 | Rueda Acero 167 mm | 10 |
| 460 | Rueda Nylon 167 mm | 10 |
| Inox Stainless Steel | | AISI 316 |
| 468 | 167 mm INOX | 10 |
| 4683 | Rueda Nylon 167 mm INOX | 10 |



Rollapar colgadero simple U-40
U-40 Simple trolley | Monture simple U-40 fixation sur plat | Rodizio pendurado simple

| Cod. | Medidas - Dimensions | |
|-------------------------------|----------------------------------|-----------------|
| 4604 | U-40 Acero Steel Acier Aço | 6 |
| 4603 | U-40 Nylon | 6 |
| Inox Stainless Steel | | AISI 316 |
| 46030 | U-40 Nylon Inox | 6 |



Rollapar doble U-40 E300
U-40 Double trolley | Monture à galets double U-40 | Rodizio duplo U-40

| Cod. | Medidas - Dimensions | |
|-------------------------------|-------------------------|-----------------|
| 466 | Rueda Acero 167 mm | 8 |
| 463 | Rueda Nylon 167 mm | 8 |
| Inox Stainless Steel | | AISI 316 |
| 469 | 167 mm INOX | 8 |
| 4693 | Rueda Nylon 167 mm INOX | 8 |



Rollapar colgadero doble U-40
U-40 Double trolley | Monture double U-40 fixation sur plat | Rodizio pendurado duplo

| Cod. | Medidas - Dimensions | |
|-------------------------------|----------------------------------|-----------------|
| 4634 | U-40 Acero Steel Acier Aço | 8 |
| 4632 | U-40 Nylon | 8 |
| Inox Stainless Steel | | AISI 316 |
| 46320 | U-40 Nylon INOX | 8 |



Rollapar U-40 nylon corto
U-40 Short nylon trolley | Monture à galets U-40 nylon courte | Rodizio U-40 nylon curto

| Cod. | Medidas - Dimensions | |
|------|----------------------------|----|
| 4612 | Simple U-40 137 mm | 10 |
| 4662 | Doble Double U-40 137 mm | 8 |



Rollapar simple U-40 soldar extremo
U-40 End simple trolley to weld
Monture à galets simple d'extrémité à souder U-40
Rodizio simple U-40 soldar extremo

| Cod. | Medidas - Dimensions | |
|-------------------------------|----------------------|-----------------|
| 461SE | Simple U-40 | 6 |
| Inox Stainless Steel | | AISI 316 |
| 468SE | Simple U-40 INOX | 6 |



Rollapar simple U-40 soldar central
U-40 Middle simple trolley to weld
Monture à galets simple intermédiaire à souder U-40
Rodizio simple U-40 soldar central

| Cod. | Medidas - Dimensions | |
|-------------------------------|----------------------|-----------------|
| 461S | Simple U-40 | 6 |
| Inox Stainless Steel | | AISI 316 |
| 468S | Simple U-40 INOX | 6 |

Gama U-40

U-40 Range | Gamme U-40



Rollapar doble U-40 soldar central
 U-40 Middle double trolley to weld
 Monture à galets double intermédiaire à souder U-40
 Rodízio duplo U-40 soldar central

| Cod. | Medidas - Dimensions | |
|-------------------------------|--------------------------|-----------------|
| 466S | Doble U-40 | 6 |
| Inox Stainless Steel | | AISI 316 |
| 469S | Doble Double U-40 INOX | 6 |



Rollapar simple U-40 atornillar extremo nylon
 U-40 End simple trolley in nylon to screw
 Monture à galets d'extrémité en nylon à visser U-40
 Rodízio simple U-40 parafusar extremo nylon

| Cod. | Medidas - Dimensions | |
|-------|----------------------|---|
| 461AE | Simple U-40 | 6 |



Rollapar simple U-40 atornillar central nylon
 U-40 Middle simple trolley in nylon to screw
 Monture à galets intermédiaire nylon à visser U-40
 Rodízio U-40 parafusar central nylon

| Cod. | Medidas - Dimensions | |
|------|----------------------|---|
| 461A | Simple U-40 | 6 |



Rollapar doble U-40 atornillar central nylon
 U-40 double Middle trolley in nylon to screw
 Monture à galets intermédiaire nylon à visser U-40
 Rodízio duplo U-40 parafusar central nylon

| Cod. | Medidas - Dimensions | |
|------|----------------------|---|
| 466A | Doble Double U-40 | 6 |

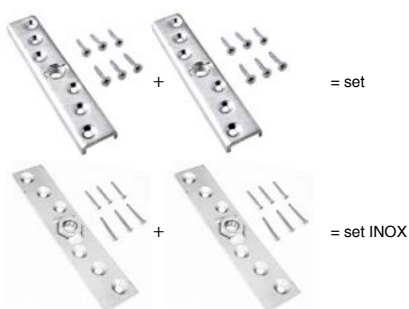

Set adaptador a madera para rollapar
 Hanging plates set | Set adaptateur à bois |
 Set de adaptação a madeira

| Cod. | Para For Pour | |
|-------------------------------|-------------------|-----------------|
| 46010 | U-40 | 5 set |
| Inox Stainless Steel | | AISI 316 |
| 46011 | U-40 INOX | 5 set |



Abrazadera soldar para rail U-40
 U-40 Track bracket to weld | Support à souder |
 Abraçadeira soldar

| Cod. | Para For Pour | |
|-------------------------------|-------------------|-----------------|
| 4783 | U-40 | 8 |
| Inox Stainless Steel | | AISI 316 |
| 47830 | U-40 INOX | 3 |



Abrazadera a pared con tornillo U-40
 U-40 Track wall bracket | Support à mur vissé |
 Abraçadeira parede com parafuso

| Cod. | Para For Pour | |
|------|-------------------|---|
| 4784 | U-40 | 8 |



Abrazadera a pared soldada U-40
 U-40 Welded track wall bracket | Support à mur
 soudé | Abraçadeira parede soldada

| Cod. | Para For Pour | |
|-------------------------------|-------------------|-----------------|
| 4785 | U-40 | 8 |
| Inox Stainless Steel | | AISI 316 |
| 47850 | U-40 INOX | 3 |



Abrazadera ajustable para rail U-40
 U-40 Track hanging bracket with bolt | Support
 réglable | Abraçadeira ajustável

| Cod. | Para For Pour | |
|-------------------------------|-------------------|-----------------|
| 4786 | U-40 | 8 |
| Inox Stainless Steel | | AISI 316 |
| 47860 | U-40 INOX | 3 |



Abrazadera a techo para rail U-40
 U-40 Track ceiling bracket | Support à plafond |
 Abraçadeira para teto

| Cod. | Para For Pour | |
|-------------------------------|-------------------|-----------------|
| 4787 | U-40 | 8 |
| Inox Stainless Steel | | AISI 316 |
| 47870 | U-40 INOX | 3 |



Empalme para rail U-40
 U-40 Joining bracket | Joint pour rail U-40 |
 Conexão para trilho U-40

| Cod. | Para For Pour | |
|-------------------------------|-------------------|-----------------|
| 47810 | U-40 | 3 |
| Inox Stainless Steel | | AISI 316 |
| 47811 | U-40 INOX | 3 |



Curva inferior U-19 para U-40
 Bottom bend | Courbe inférieure | Curva inferior

| Cod. | Para For Pour | |
|-------------------------------|--------------------------|-----------------|
| 481 | U-19 para Rail U-40 | 1 |
| Inox Stainless Steel | | AISI 316 |
| 4810 | U-19 para Rail U-40 INOX | 1 |



Gama U-60

E240 - E450

U-60 Range | Gamme U-60



Rail superior U-60
U-60 Top track | Rail supérieur U-60 | Trilho superior U-60

| Cod. | Medidas - Dimensions | ±1% |
|-------------------------------|----------------------|-----|
| 479 | U-60 | 3 m |
| Inox Stainless Steel | | |
| 485 | U-60 INOX AISI 304 | 3 m |
| 48516 | U-60 INOX AISI 316 | 3 m |



Curva superior U-60
U-60 Top bend | Courbe supérieure U-60 | Curva superior U-60

| Cod. | Medidas - Dimensions | |
|-------------------------------|----------------------|---|
| 480 | U-60 | 1 |
| Inox Stainless Steel | | |
| 4804 | U-60 INOX AISI 304 | 1 |
| 4806 | U-60 INOX AISI 316 | 1 |



Tope rail U-60
U-60 Top track stopper for rails | Butée rail U-60 | Topo guia U-60

| Cod. | Para For Pour | |
|------|-------------------|---|
| F479 | U-60 | 6 |



Rollapar simple U-60 E240
U-60 Simple trolley | Monture à galets simple U-60 | Rodízio simple U-60

| Cod. | Medidas - Dimensions | |
|-------------------------------|----------------------|---|
| 4625 | U-60 Acero 180 mm | 6 |
| 462 | U-60 Nylon 180 mm | 6 |
| Inox Stainless Steel | | |
| 483 | U-60 180 mm INOX | 6 |



Rollapar doble U-60 E450
U-60 Double trolley | Monture à galets double U-60 | Rodízio duplo U-60

| Cod. | Medidas - Dimensions | |
|-------------------------------|----------------------|---|
| 4675 | U-60 Acero 180 mm | 4 |
| 467 | U-60 Nylon 180 mm | 4 |
| Inox Stainless Steel | | |
| 484 | U-60 180 mm INOX | 4 |



Vídeo



Rollapar U-60 nylon corto E450
U-60 Trolley nylon short | Monture à galets U-60 nylon courte | Rodízio U-60 nylon curto

| Cod. | Medidas - Dimensions | |
|------|----------------------------|---|
| 4672 | Doble Double U-60 150 mm | 4 |



Rollapar simple U-60 soldar extremo
U-60 End simple trolley to weld
Monture à galets simple d'extrémité à souder
Rodízio simple U-60 soldar extremo

| Cod. | Medidas - Dimensions | |
|-------------------------------|----------------------|---|
| 462SE | Simple U-60 | 4 |
| Inox Stainless Steel | | |
| 483SE | Simple U-60 INOX | 4 |



Rollapar doble U-60 soldar central
U-60 Middle double trolley to weld
Monture à galets double intermédiaire à souder
Rodízio duplo U-60 soldar central

| Cod. | Medidas - Dimensions | |
|-------------------------------|--------------------------|---|
| 467S | Doble Double U-60 | 4 |
| Inox Stainless Steel | | |
| 484S | Doble Double U-60 INOX | 4 |



Rollapar simple U-60 atornillar extremo
U-60 End simple trolley to screw
Monture à galets simple d'extrémité à visser U-60
Rodízio simple U-60 parafusar extremo

| Cod. | Medidas - Dimensions | |
|-------|----------------------|---|
| 462AE | Simple U-60 | 6 |



Rollapar doble U-60 atornillar central
U-60 Middle double trolley to screw
Monture à galets double intermédiaire à visser U-60
Rodízio duplo U-60 parafusar central

| Cod. | Medidas - Dimensions | |
|------|----------------------|---|
| 467A | Doble Double U-60 | 4 |

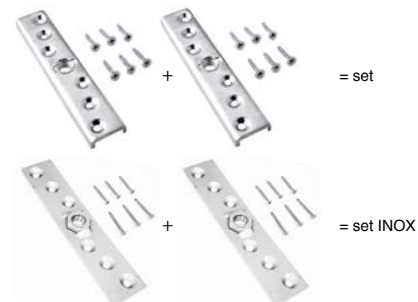

Set adaptador a madera para rollapar
Hanging plates set | Set adaptateur à bois | Set de adaptação a madeira

| Cod. | Para For Pour | |
|-------------------------------|-------------------|-------|
| 46010 | U-60 | 5 set |
| Inox Stainless Steel | | |
| 46011 | U-60 INOX | 5 set |

Gama U-60

U-60 Range | Gamme U-60



Abrazadera soldar para raíl U-60
U-60 Track bracket to weld | Support à souder | Abraçadeira soldar

| Cod. | Para For Pour | |
|-------------------------------|-------------------|-----------------|
| 4793 | U-60 | 5 |
| Inox Stainless Steel | | AISI 316 |
| 47930 | U-60 INOX | 3 |



Abrazadera a pared con tornillo U-60
U-60 Track wall bracket | Support à mur vissé | Abraçadeira parede com parafuso

| Cod. | Para For Pour | |
|------|-------------------|---|
| 4794 | U-60 | 5 |



Abrazadera a pared soldada U-60
U-60 Welded track wall bracket | Support à mur soudé | Abraçadeira parede soldada

| Cod. | Para For Pour | |
|-------------------------------|-------------------|-----------------|
| 4795 | U-60 | 5 |
| Inox Stainless Steel | | AISI 316 |
| 47950 | U-60 INOX | 3 |



Abrazadera ajustable para raíl U-60
U-60 Track hanging bracket with bolt | Support réglable | Abraçadeira ajustável

| Cod. | Para For Pour | |
|-------------------------------|-------------------|-----------------|
| 4796 | U-60 | 5 |
| Inox Stainless Steel | | AISI 316 |
| 47960 | U-60 INOX | 3 |



Empalme para raíl U-60
U-60 Joining bracket | Joint pour rail U-60 | Conexão para trilho

| Cod. | Para For Pour | |
|-------------------------------|-------------------|-----------------|
| 47910 | U-60 | 2 |
| Inox Stainless Steel | | AISI 316 |
| 47911 | U-60 INOX | 2 |



Curva inferior U-19 para U-60
Bottom bend | Courbe inférieure | Curva inferior

| Cod. | Medidas - Dimensions | |
|-------------------------------|--------------------------|-----------------|
| 4811 | U-19 para Raíl U-60 | 1 |
| Inox Stainless Steel | | AISI 316 |
| 48110 | U-19 para Raíl U-60 INOX | 1 |

Accesorios

Accessories | Accessoires | Acessórios



N
EGRO
BLACK
NOIR
PRETO

Tirador acero negro
Handle black steel | Poignée acier noir | Puxador aço preto

| Cod. | Medidas - Dimensions | |
|-------|----------------------|---|
| 9932N | 160x30 | 4 |
| 9922N | 270x40 | 2 |



Z
INCADO
ZINC
ZINGÉ
ZINCADO

Tirador acero zincado
Handle zinc plated | Poignée acier zingué | Puxador aço zincado

| Cod. | Medidas - Dimensions | |
|-------|----------------------|---|
| 9932Z | 160x30 | 4 |
| 9922Z | 270x40 | 2 |



Pernio gota con arandela de latón
Drop profile hinge | Paumelle profil goutte | Perno gota

| Cod. | Medidas - Dimensions | |
|-------------------------------|----------------------|-----------------|
| 48 | 20x120 | 18 |
| Inox Stainless Steel | | AISI 316 |
| 712 | 20x120 INOX | 10 |



Bisagra medio
Middle hinge | Charnière intermédiaire | Dobradiça meio

| Cod. | Para For Pour | |
|------|--|----|
| 6955 | Atornillar Screw-on Visser Parafusar | 10 |



Guiador inferior U-19
U-19 Bottom guide | Guide inférieur U-19 | Guia inferior U-19

| Cod. | Para For Pour | |
|-------------------------------|-------------------|-----------------|
| 790 | U-19 | 8 |
| Inox Stainless Steel | | AISI 316 |
| 791 | U-19 INOX | 8 |



Guiador inferior U-19 nylon
U-19 Bottom guide in nylon | Guide inférieur U-19 nylon | Guia inferior U-19 nylon

| Cod. | Para For Pour | |
|-------------------------------|-------------------|-----------------|
| 792 | U-19 Nylon | 8 |
| Inox Stainless Steel | | AISI 316 |
| 794 | U-19 Nylon INOX | 8 |



Accesorios

Accessories | Accessoires | Acessórios



Guiador inferior soldar extremo U-19
U-19 End bottom guide to weld
Guide inférieur d'extrémité à souder U-19
Guiia inferior soldar extremo U-19

| Cod. | Para For Pour | |
|-------------------------------|-------------------|---|
| 780E | U-19 | 6 |
| Inox Stainless Steel | AISI 316 | |
| 781E | U-19 INOX | 6 |



Guiador inferior soldar central U-19
U-19 Middle bottom guide to weld
Guide inférieur intermédiaire à souder U-19
Guiia inferior soldar central U-19

| Cod. | Para For Pour | |
|-------------------------------|-------------------|----|
| 780 | U-19 | 10 |
| Inox Stainless Steel | AISI 316 | |
| 781 | U-19 INOX | 10 |



Guiador inferior atornillar extremo U-19
U-19 End bottom guide to screw
Guide inférieur d'extrémité à visser U-19
Guiia inferior parafusar extremo U-19

| Cod. | Para For Pour | |
|------|-------------------|---|
| 770E | U-19 | 8 |



Guiador inferior atornillar central U-19
U-19 Middle bottom guide to screw
Guide inférieur intermédiaire à visser U-19
Guiia inferior parafusar central U-19

| Cod. | Para For Pour | |
|------|-------------------|---|
| 770 | U-19 | 8 |



Guiador a suelo de plástico
Plastic floor guide
Guide à sol en plastique
Guiia solo plastico

| Cod. | Medidas - Dimensions | |
|------|----------------------|----|
| 5006 | 46,5x15 | 10 |



Guiadores inferiores atornillar U-19
U-19 Bottom guides to screw
Guides inférieurs à visser U-19
Guiias inferiores parafusar U-19

| Cod. | Para For Pour | |
|-------|----------------------------|----|
| 25192 | U-19 Acero Steel Acier | 10 |
| 25199 | U-19 Nylon | 10 |
| 25195 | U-19 Estrecho Narrow | 20 |



Guía inferior encarcelar simple
Simple guide to fit
Guide simple à sceller
Guiia inferior encarcelar simple

| Cod. | | |
|-------|--------|---|
| 47110 | Simple | 2 |



Guía inferior encarcelar doble
Double guide to fit
Guide double à sceller
Guiia inferior encarcelar duplo

| Cod. | Medidas - Dimensions | |
|-------|----------------------|---|
| 47120 | 32-85 Doble Double | 2 |



Guía inferior atornillar simple
Simple guide to screw | Guide simple à visser |
Guiia inferior atornillar simple

| Cod. | | |
|-------|--------|---|
| 47130 | Simple | 2 |



Guía inferior atornillar doble
Double guide to screw | Guide double à visser |
Guiia inferior atornillar duplo

| Cod. | Medidas - Dimensions | |
|-------|-----------------------|---|
| 47140 | 18-128 Doble Double | 2 |



Raíl inferior U-19
U-19 Bottom track | Rail inférieur | Trilho inferior

| Cod. | Medidas - Dimensions | |
|-------------------------------|----------------------|-----|
| 474 | U-19 e= 3mm | 3 m |
| 475 | U-19 e= 1,2mm | 3 m |
| Inox Stainless Steel | AISI 316 | |
| 486 | U-19 INOX e= 2mm | 3 m |



Raíl inferior O-19
O-19 Bottom track | Rail inférieur | Trilho inferior

| Cod. | Medidas - Dimensions | |
|------|----------------------|-----|
| 471 | Omega 19 mm | 3 m |



Freno
Brake | Frein | Freio

| Cod. | Medidas - Dimensions | |
|------|----------------------|---|
| 5806 | 120 mm | 8 |



Freno radial ajustable
Adjustable radial brake | Frein radial réglable |
Freio radial ajustável

| Cod. | | |
|--------|--|---|
| 470040 | | 1 |



Pistón amortiguador fin de carrera
Shock absorber piston | Piston amortisseur |
Piston amortecedor

| Cod. | Medidas - Dimensions | |
|--------|----------------------|---|
| 470030 | 95 mm | 1 |

Gama U-70

U-70 Range | Gamme U-70



Rail superior U-70
U-70 Top track
Rail supérieur U-70
Trilho superior U-70

| Cod. | Medidas - Dimensions | $\pm 1\%$ |
|------|----------------------|-----------|
| 470 | U-70 | 3 m |



Rollapar U-70 simple E1200
U-70 Simple trolley | Monture à galets simple U-70 | Rodízio U-70 simple

| Cod. | Medidas - Dimensions | |
|------|----------------------|---|
| 464L | Simple U-70 | 2 |



Rollapar U-70 doble E2000
U-70 Double trolley | Monture à galets double U-70 | Rodízio U-70 duplo

| Cod. | Medidas - Dimensions | |
|------|----------------------|---|
| 465L | Doble Double U-70 | 2 |



Rollapar U-70 simple E1200 AXIAL
U-70 Ball bearing simple trolley | Monture à galets simple U-70 axial | Rodízio U-70 simple axial

| Cod. | Medidas - Dimensions | |
|------|----------------------|---|
| 4642 | Simple U-70 AXIAL | 2 |



Rollapar U-70 doble E2000 AXIAL
U-70 Ball bearing double trolley | Monture à galets double U-70 axial | Rodízio U-70 duplo axial

| Cod. | Medidas - Dimensions | |
|------|---------------------------|---|
| 4652 | Doble Double U-70 AXIAL | 2 |



Tope rail U-70
U-70 Top track stopper for rail | Butée rail U-70 | Topo guia U-70

| Cod. | Para For Pour | |
|-------|-------------------|---|
| 47201 | U-70 | 4 |



Fijación a pared para abrazadera U-70
Fixation to wall for U-70 support
Equerre à visser pour support réglable U-70
Escuadra parafusar abraçadeira U-70

| Cod. | Medidas - Dimensions | |
|-------|----------------------|---|
| 47002 | U-70 | 4 |



Abrazadera raíl U-70 ajustable
U-70 Track hanging bracket | Support réglable rail U-70 | Abraçadeira trilho U-70 ajustável

| Cod. | Medidas - Dimensions | |
|--------|----------------------|---|
| 47001L | U-70 | 2 |



Empalme para raíl U-70
U-70 Joining bracket | Joint pour rail U-70 | Conexão para trilho U-70

| Cod. | Medidas - Dimensions | |
|--------|----------------------|---|
| 470010 | U-70 | 2 |



Fijación regulable para abrazaderas U-70
Regulating fixation, to screw, for U-70 supports
Fixation réglable à visser pour supports U-70
Fixação regulável parafusar abraçadeira U-70

| Cod. | Medidas - Dimensions | $\pm 1\%$ |
|-------|----------------------|-----------|
| 47003 | U-70 | 2 |



Guiador inferior U-50
U-50 Bottom guide | Guide inférieur U-50 | Guia inferior U-50

| Cod. | Medidas - Dimensions | |
|------|----------------------|---|
| 5026 | U-50 | 5 |



Raíl inferior U-50
U-50 Bottom track | Rail inférieur U-50 | Trilho inferior U-50

| Cod. | Medidas - Dimensions | $\pm 1\%$ |
|------|----------------------|-----------|
| 5020 | U-50 | 3 m |



Herrajes Puertas Correderas Rústicas

Barn Sliding Gates Hardware

Ferrures pour Portes Coulissantes Rustiques

Ferragens Portas Corrediças Rusticas



Pletinas
Poleas granero
Empalme
Tope
Separador
Kits herrajes granero



Plates
Rustic wheels
Plate joint
Rustic stopper
Wall spacers
Rustic door Kits



Platines
Roues portails agricoles
Manchon de raccordement pour platine
Rutée rustique
Séparateur de mur
Kits porte rustique



Platinas
Pólias tipo celeiro
Conexão para platina
Topo rustico
Separador parede
Kits porta rustica



Kits Herrajes Granero - Blanco

Barn door kit - White | Kit porte rustique - Blanc | Kit porta rustica - Branco

B
LANCO
WHITE
BLANC
BRANCO



Kits herrajes granero - Polea Nylon
Rustic door kits | Kits portes rustiques | Kits porta rustica

| Cod. | Pletina | Polea Nylon | | |
|---------------|-----------|-------------|--------|---|
| Ø 60 | | | | |
| KG230B | 30x5x2000 | 60x15 | 5 unid | 1 |

ES: Acabado blanco: pletina, topos rústicos y separadores a pared
EN: White finish: Plate, rustic stoppers and wall separators
FR: Finition blanche: butées rustiques et séparateurs de mur
PO: Acabamento branco: Platina, topos rusticos e separadores parede

Incluye tornillería e instrucciones

Kits Herrajes Granero Doble - Negro

Barn double door kit - Black | Kit double porte rustique - Noir | Kit porta rustica duplo - Preto

N
EGRO
BLACK
NOIR
PRETO



Kits herrajes granero - Polea Nylon
Rustic door kits | Kits portes rustiques | Kits porta rustica

| Cod. | Pletina | Polea Nylon | | |
|----------------|-----------|-------------|--------|---|
| Ø 60 | | | | |
| KG330ND | 30x5x3000 | 60x15 | 8 unid | 1 |



Video

Incluye tornillería e instrucciones

Instalaciones

Installations | Installations | Colocações

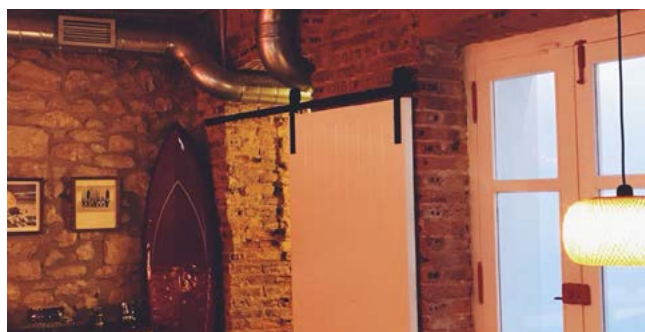
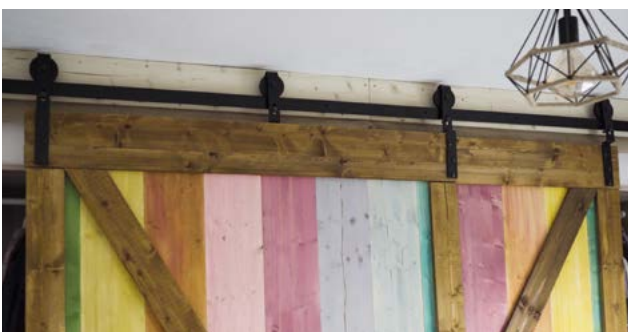
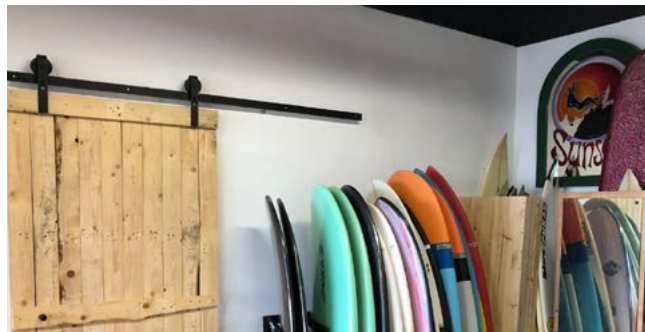

Kits Herrajes Granero

Rustic door kits | Kits portes rustiques | Kits portas rusticas



Z
INCADO
ZINC
ZINGÉ
ZINCADO



Incluyen tornillería e instrucciones



N
EGRO
BLACK
NOIR
PRETO



Incluyen tornillería e instrucciones

Kits herrajes granero - Zincado Rustic door kits | Kits portes rustiques | Kits porta rustica

| Cod. | Cod. | Pletina | Medidas Polea |  |  |
|---------------|---------------|-----------|---------------|---|---|
| Rueda Nylon | Rueda Acero | | Ø 60 | | |
| KG1830 | KG1830 | 30x5x1800 | 60x15 | 5 unid | 1 |
| KG230 | KG230 | 30x5x2000 | 60x15 | 5 unid | 1 |
| KG330 | KG330 | 30x5x3000 | 60x15 | 8 unid | 1 |

| Rueda Nylon | Rueda Acero | | Ø 90 | | |
|---------------|---------------|-----------|-------|--------|---|
| KG1845 | KG1845 | 45x8x1800 | 90x19 | 5 unid | 1 |
| KG245 | KG245 | 45x8x2000 | 90x19 | 5 unid | 1 |
| KG345 | KG345 | 45x8x3000 | 90x19 | 8 unid | 1 |

Kits herrajes granero - Negro Rustic door kits | Kits portes rustiques | Kits porta rustica

| Cod. | Cod. | Pletina | Medidas Polea |  |  |
|----------------|----------------|-----------|---------------|---|---|
| Rueda Nylon | Rueda Acero | | Ø 60 | | |
| KG1830N | KG1830N | 30x5x1800 | 60x15 | 5 unid | 1 |
| KG230N | KG230N | 30x5x2000 | 60x15 | 5 unid | 1 |
| KG330N | KG330N | 30x5x3000 | 60x15 | 8 unid | 1 |

| Rueda Nylon | Rueda Acero | | Ø 90 | | |
|----------------|----------------|-----------|-------|--------|---|
| KG1845N | KG1845N | 45x8x1800 | 90x19 | 5 unid | 1 |
| KG245N | KG245N | 45x8x2000 | 90x19 | 5 unid | 1 |
| KG345N | KG345N | 45x8x3000 | 90x19 | 8 unid | 1 |

Colocación y montaje puerta rústica simple - PASOS

Installation and assembly - STEPS | Installation et montage - ÉTAPES | Colocação e montagem - ESTÁGIOS



Vídeo



1



2



3



4

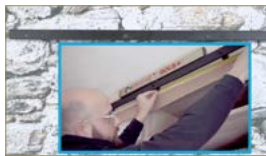

5



6



7



8



9



10



11



12



13



14



15



16

P
EQUEÑO

SMALL
PETITE
PEQUEÑO

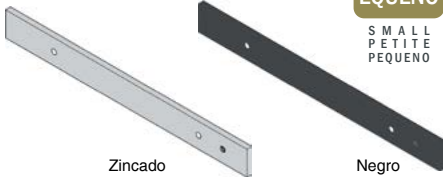

Zincado

Negro

Pletina 30x5
Plate | Platine | Platina

| Cod. | Acabado Finish Finition Acabamento | | |
|----------|---|---------|-------|
| PL30518 | 30x5 | Zincado | 1,8 m |
| PL3052 | 30x5 | Zincado | 2 m |
| PL3053 | 30x5 | Zincado | 3 m |
| PL30518N | 30x5 | Negro | 1,8 m |
| PL3052N | 30x5 | Negro | 2 m |
| PL3053N | 30x5 | Negro | 3 m |

M
EDIANO

MEDIUM
MOYENNE
MEDIANO



Zincado

Negro

Pletina 45x8
Plate | Platine | Platina

| Cod. | Acabado Finish Finition Acabamento | | |
|----------|---|---------|-------|
| PL45818 | 45x8 | Zincado | 1,8 m |
| PL4582 | 45x8 | Zincado | 2 m |
| PL4583 | 45x8 | Zincado | 3 m |
| PL45818N | 45x8 | Negro | 1,8 m |
| PL4582N | 45x8 | Negro | 2 m |
| PL4583N | 45x8 | Negro | 3 m |

G
RANDE

BIG
GRANDE
GRANDE



Zincado

Negro

Pletina 50x10
Plate | Platine | Platina

| Cod. | Acabado Finish Finition Acabamento | | |
|-----------|---|---------|-------|
| PL501018 | 50x10 | Zincado | 1,8 m |
| PL50102 | 50x10 | Zincado | 2 m |
| PL50103 | 50x10 | Zincado | 3 m |
| PL501018N | 50x10 | Negro | 1,8 m |
| PL50102N | 50x10 | Negro | 2 m |
| PL50103N | 50x10 | Negro | 3 m |



Poleas granero Zincado - Rueda Nylon
Zinc plated rustic wheels | Roues portails agricoles zinguées | Polias tipo celeiro zincado

| Cod. | Medidas - Dimensions | |
|-------|----------------------|---|
| 57539 | 60x15 mm | 1 |
| 57549 | 90x19 mm | 1 |
| 57559 | 120x22 mm | 1 |



Poleas granero Negro - Rueda Nylon
Black rustic wheels | Roues portails agricoles noir | Polias tipo celeiro preto

| Cod. | Medidas - Dimensions | |
|--------|----------------------|---|
| 57539N | 60x15 mm | 1 |
| 57549N | 90x19 mm | 1 |
| 57559N | 120x22 mm | 1 |



Poleas granero Zincado - Rueda Acero
Zinc plated rustic wheels | Roues portails agricoles zinguées | Polias tipo celeiro zincado

| Cod. | Medidas - Dimensions | |
|------|----------------------|---|
| 5753 | 60x15 mm | 1 |
| 5754 | 90x19 mm | 1 |
| 5755 | 120x22 mm | 1 |



Poleas granero Negro - Rueda Acero
Black rustic wheels | Roues portails agricoles noir | Polias tipo celeiro preto

| Cod. | Medidas - Dimensions | |
|-------|----------------------|---|
| 5753N | 60x15 mm | 1 |
| 5754N | 90x19 mm | 1 |
| 5755N | 120x22 mm | 1 |



Poleas granero doble Negro - Rueda Nylon
Double black rustic wheels | Roues portails agricoles double noir | Polias tipo celeiro preto duplo

| Cod. | Medidas - Dimensions | |
|---------|----------------------|-------------|
| 575300N | 60x15 mm | Delantera 1 |
| 575301N | 60x15 mm | Trasera 1 |
| 575400N | 90x19 mm | Delantera 1 |
| 575401N | 90x19 mm | Trasera 1 |



Vídeo

Trasera
Back
Derrière
Traseiro

Delantera
Front
Devant
Dianteiro



Empalme pletina
Plate joint | Manchon de raccordement pour platine | Conexão para platina

| Cod. | Medidas - Dimensions | |
|--------|----------------------|---|
| E305N | 30x5 mm | 1 |
| E458N | 45x8 mm | 1 |
| E5010N | 50x10 mm | 1 |



Tope rústico negro
Rustic stopper | Butée rustique | Topo rustico

| Cod. | Medidas - Dimensions | |
|------|----------------------|---|
| 575N | 60-90 | 6 |



Separador pared negro
Black wall spacers | Séparateur de mur noir | Separador parede preto

| Cod. | Medidas - Dimensions | |
|--------|----------------------|----|
| 57533N | Polea 60 | 16 |
| 57543N | Polea 90 | 16 |
| 57553N | Polea 120 | 8 |



Guiador a suelo de plástico
Plastic floor guide | Guide à sol en plastique | Guia solo plastico

| Cod. | Medidas - Dimensions | |
|------|----------------------|----|
| 5006 | 46,5x15 | 10 |



Herrajes Puertas de Cancela

Swing Gates Hardware

Ferrures pour Portails

Ferragens Portas de Cancela

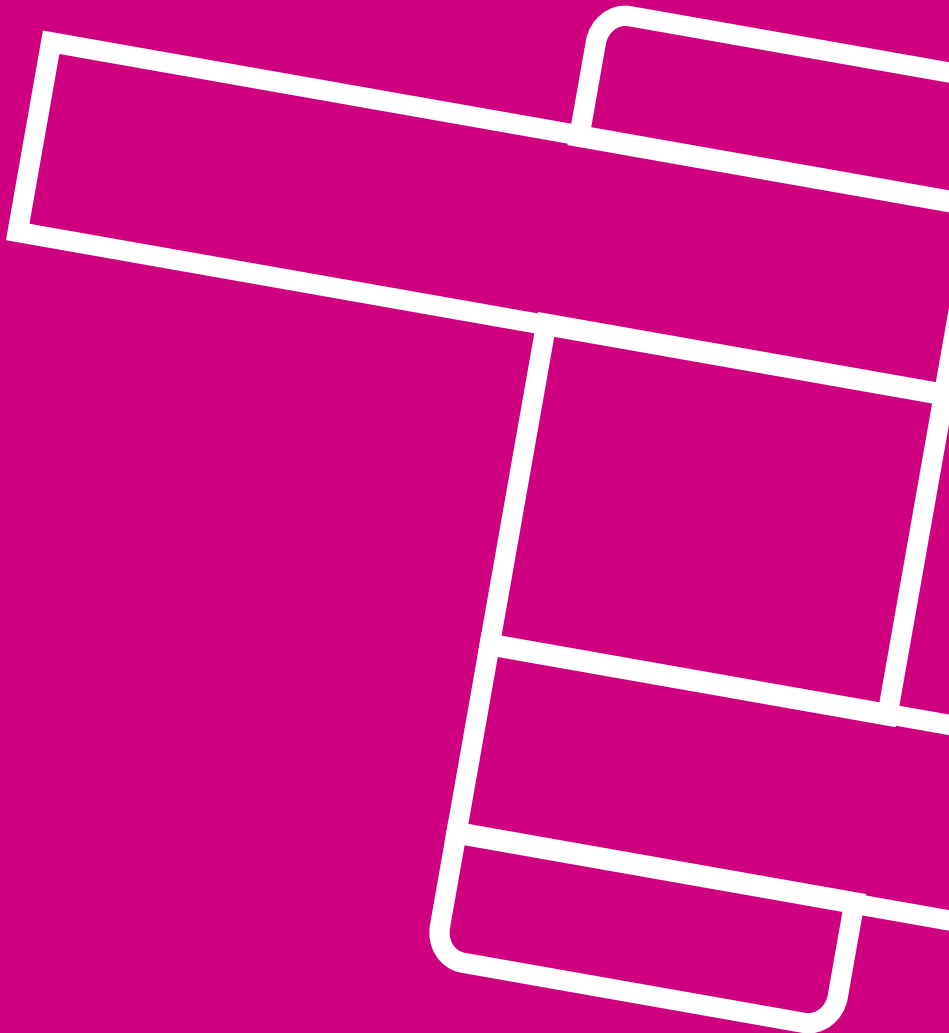

Pernio inferior con bola
Bisagra regulable con dado
Punto de giro cuadrado
Punto de giro a bola
Puntos de giro con rodamiento
Puntos de giro para grandes pesos
Topes puertas
Manetas regulables



Bottom pivot with ball
Adjustable wrap-around hinge
Square pivot hinge
Pivot hinges with ball
Pivot hinges with bearing
Pivot hinges for heavy duty gates
Gate stoppers
Adjustable handles



Pivot inférieur
Gond réglable
Pivot carré
Pivot avec bille
Pivots avec roulement
Pivots pour charges lourdes
Arrêt de portails
Poignées réglable



Perno inferior com bola
Dobradiça regulável
Ponto de rotação a quadrado
Ponto de rotação a bola
Ponto de rotação com rolamento
Pontos de rotação para pesos pesados
Topo portas
Maneta regulável



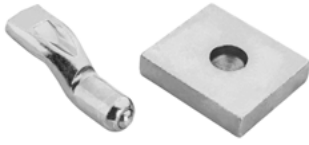

Pernio inferior con bola | Bottom pivot with ball | Pivot inférieur avec bille | Perno inferior com bola

| Cod. | Medidas - Dimensions | |
|------|----------------------|----|
| 563 | 20 mm | 10 |
| 564 | 24 mm | 6 |



Bisagra regulable con dado | Adjustable wrap around hinge | Gond réglable | Dobradiça regulável

| Cod. | Medidas - Dimensions | |
|------|------------------------------|----|
| 565 | M.20 | 20 |
| 569 | Placa Back plate Platine | 18 |



Punto de giro cuadrado | Square pivot hinge | Pivot carré | Ponto de rotação a quadrado

| Cod. | Medidas - Dimensions | |
|------|--------------------------------|---|
| 593 | 30x40 Juego Set Jeu Jogo | 1 |
| 594 | 35x40 Juego Set Jeu Jogo | 1 |
| 597 | 40x40 Juego Set Jeu Jogo | 1 |



Punto de giro 40 mm a bola | Pivot hinge with ball 40 mm | Pivot 40 mm avec bille | Ponto de rotação a bola 40 mm

| Cod. | Medidas - Dimensions | |
|------|--------------------------------|----|
| 165 | 40 mm Juego Set Jeu Jogo | 4 |
| 1651 | 40 mm Superior Supérieur | 10 |
| 1652 | 40 mm Inferior Inférieur | 10 |



Punto de giro 42 mm con rodamiento | Pivot hinge with bearing 42 mm | Pivot 42 mm avec roulement | Ponto de rotação com rolamento 42 mm

| Cod. | Medidas - Dimensions | |
|-------------------------------|--------------------------------|---------------------|
| 175 | 42 mm Juego Set Jeu Jogo | 3 |
| 1751 | 42 mm Superior Supérieur | 3 |
| 1752* | 42 mm Inferior Inférieur | 6 |
| Inox Stainless Steel | | AISI 303-304 |
| 591 | 42 mm Juego Set | 1 |
| 5911 | 42 mm Superior Supérieur | 2 |
| 5912* | 42 mm Inferior Inférieur | 2 |



Punto de giro 50 mm con rodamiento | Pivot hinge with bearing 50 mm | Pivot 50 mm avec roulement | Ponto de rotação com rolamento 50 mm

| Cod. | Medidas - Dimensions | |
|-------|--------------------------------|---|
| 292 | 50 mm Juego Set Jeu Jogo | 2 |
| 2921 | 50 mm Superior Supérieur | 6 |
| 2922* | 50 mm Inferior Inférieur | 6 |



Vídeo

Punto de giro 50 mm atornillar con rodamiento | Pivot hinge to screw 50 mm | Pivot 50 mm à risser | Ponto de rotação com rolamento 50 mm

| Cod. | Medidas - Dimensions | |
|-------|--------------------------------|---|
| 293 | 50 mm Juego Set Jeu Jogo | 2 |
| 2931 | 50 mm Superior Supérieur | 4 |
| 2932* | 50 mm Inferior Inférieur | 4 |



Punto de giro 60 mm con rodamiento | Pivot hinge with bearing 60 mm | Pivot 60 mm avec roulement | Ponto de rotação com rolamento 60 mm

| Cod. | Medidas - Dimensions | |
|-------------------------------|--------------------------------|---------------------|
| 337 | 60 mm Juego Set Jeu Jogo | 1 |
| 3371 | 60 mm Superior Supérieur | 2 |
| 3372* | 60 mm Inferior Inférieur | 4 |
| Inox Stainless Steel | | AISI 303-304 |
| 590 | 60 mm Juego Set | 1 |
| 5902 | 60 mm Superior Supérieur | 2 |
| 5903* | 60 mm Inferior Inférieur | 2 |



Punto de giro 70 mm con rodamiento | Pivot hinge with bearing 70 mm | Pivot 70 mm avec roulement | Ponto de rotação com rolamento 70 mm

| Cod. | Medidas - Dimensions | |
|-------|--------------------------------|---|
| 166 | 70 mm Juego Set Jeu Jogo | 1 |
| 1661 | 70 mm Superior Supérieur | 2 |
| 1662* | 70 mm Inferior Inférieur | 4 |



Puntos de giro para grandes pesos | Pivot hinges for heavy duty gates | Pivots pour charges lourdes | Pontos de rotação para pesos pesados

| Cod. | Medidas - Dimensions | |
|------|---------------------------------|---|
| 294* | 90 mm Juego Set Jeu Jogo | 1 |
| 295* | 120 mm Juego Set Jeu Jogo | 1 |



Topo puertas | Gate stopper | Arrêt de portails | Topo portas

| Cod. | Medidas - Dimensions | |
|------|---|---|
| 578 | Redondo Round Rond | 9 |
| 584 | Atornillar Screw Visser Parafusar | 6 |
| 585 | Encarcelar Fit Sceller Embutir | 6 |



Maneta regulable | Adjustable handle | Poignée réglable | Maneta regulável

| Cod. | Medidas - Dimensions | |
|------|----------------------------|----|
| 41 | 25:38 Negra Black Noir | 20 |
| 36 | 35:50 Negra Black Noir | 20 |
| 37 | 45:60 Negra Black Noir | 20 |
| 275 | 30:70 Negra Black Noir | 20 |
| 4101 | 25:38 Cromada Chrome | 15 |
| 38 | 35:50 Cromada Chrome | 20 |
| 39 | 45:60 Cromada Chrome | 15 |

* Incluyen junta tórica | Sealing ring included | Bague d'étanchéité incluse | Inclui o-ring

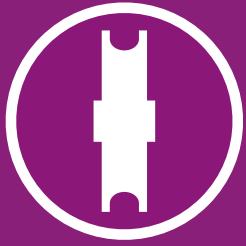

Herrajes Puertas Elevables

Overhead Gates Hardware

Ferrures pour Portes Basculantes

Ferragens Portas de Elevar

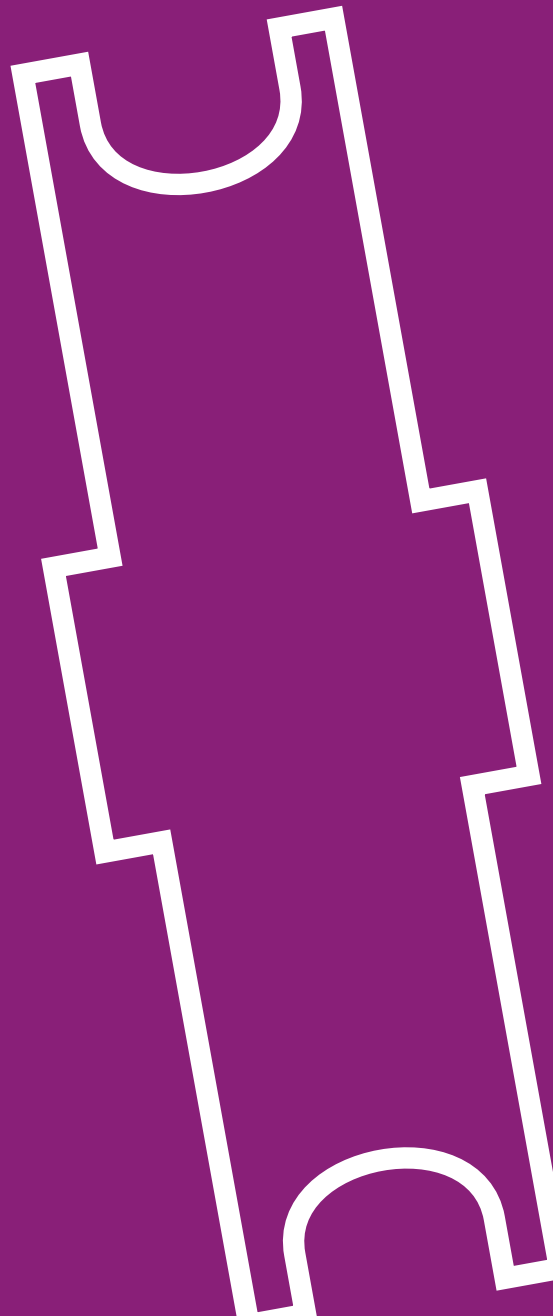

Bisagras superiores
Manillas
Poleas canal 10 mm
Poleas doble canal
Poleas canal cuadrada
Frenos de seguridad
Rodillos guía



Upper hinges
Overhead gates handle
U-10 mm wheels
Two grooves wheels
Squared groove wheels
Safety brakes
Guide roller



Charnières supérieures
Poignée portes basculantes
Galets U-10 mm
Galets deux gorges
Galets gorge carrée
Freins de sécurité
Coussinets guide



Dobradiça superior
Manilha portas elevar
Polias U-10 mm
Polias duplo canal
Polias canal quadrada
Freio segurança
Rolos guia





Bisagra ángulo superior
Upper hinge | Charnière supérieure |
Dobradiça superior

| Cod. | Medidas - Dimensions | |
|------|----------------------|----|
| 163 | 32x32 | 18 |
| 162 | 40x40 | 18 |



Bisagra ángulo superior con chapa
Upper hinge | Charnière supérieure |
Dobradiça superior

| Cod. | Medidas - Dimensions | |
|------|-------------------------------|----|
| 164 | 160x40x8 Iz/Dch Left/Right | 12 |
| 160 | 175x50x10 Iz/Dch Left/Right | 10 |



Manilla puertas elevables
Overhead doors handle | Poignée portes
basculantes | Manilha portas elevar

| Cod. | Medidas - Dimensions | |
|------|-------------------------------|----|
| 448 | Negra Black Noire Preta | 15 |
| 449 | Cromada Chromed Chromée | 15 |



**Polea canal 10 mm | U-10 mm wheel |
Galet U-10 mm | Polia U-10 mm**

| Cod. | Medidas - Dimensions | |
|------|----------------------|----|
| 100 | 45x10 | 30 |
| 101 | 60x10 | 30 |
| 102 | 70x10 | 24 |
| 103 | 80x10 | 15 |
| 104 | 90x10 | 12 |
| 105 | 100x10 | 12 |
| 106 | 120x10 | 7 |
| 111 | 150x10 | 4 |
| 116 | 180x10 | 4 |
| 112 | 200x10 | 4 |
| 143 | 250x10 | 3 |



**Polea nylon canal 10 mm | U-10 mm nylon wheel |
Galet U-10 mm nylon | Polia U-10 mm nylon**

| Cod. | Medidas - Dimensions | |
|------|----------------------|----|
| 360 | 45x10 | 30 |
| 361 | 60x10 | 30 |
| 362 | 70x10 | 24 |
| 363 | 80x10 | 15 |
| 364 | 90x10 | 12 |
| 365 | 100x10 | 12 |
| 366 | 120x10 | 7 |
| 367 | 150x10 | 4 |
| 381 | 180x10 | 4 |
| 368 | 200x10 | 4 |



**Polea doble canal | 2 grooves wheel |
Galet double gorge | Polia duplo canal**

| Cod. | Medidas - Dimensions | |
|------|----------------------|---|
| 142 | 100x29 | 8 |
| 113 | 120x29 | 4 |
| 114 | 150x29 | 4 |
| 118 | 180x29 | 4 |
| 115 | 200x29 | 4 |



Polea canal cuadrada 10 mm
10 mm square-groove wheel | Galet gorge 10 mm
carrée | Polia canal 10 mm quadrada

| Cod. | Medidas - Dimensions | |
|------|----------------------|----|
| 965 | 60x10 | 20 |
| 966 | 70x10 | 20 |
| 967 | 80x10 | 15 |
| 968 | 90x10 | 8 |
| 969 | 100x10 | 8 |
| 970 | 120x10 | 6 |



Polea canal cuadrada 20 mm
20 mm square-groove wheel | Galet gorge 20 mm
carrée | Polia canal 20 mm quadrada

| Cod. | Medidas - Dimensions | |
|------|----------------------|----|
| 973 | 80x20 | 16 |
| 974 | 90x20 | 8 |
| 975 | 100x20 | 8 |
| 976 | 120x20 | 6 |
| 977 | 150x20 | 4 |



Freno de seguridad / Paracaídas
Safety brake | Freins de sécurité |
Freio segurança

| Cod. | Medidas - Dimensions | |
|------|----------------------|-------|
| 450 | U-40 | 1 set |
| 452 | U-50 | 1 set |
| 454 | U-60 | 1 set |
| 455 | U-80 | 1 set |
| 4571 | U-100 | 1 set |
| UPN | | |
| 456 | UPN 80 | 1 set |
| 457 | UPN 100 | 1 set |



**Rodillo guía | Guide roller | Coussinet guide |
Rolo guia**

| Cod. | Medidas - Dimensions | |
|------|----------------------|----|
| 1351 | U-40 | 20 |
| 135 | U-50 | 20 |
| 136 | U-60 M.12 | 32 |
| 141 | U-60 M.16 | 26 |
| 137 | U-70 | 20 |
| 138 | U-80 | 18 |
| 139 | U-90 | 6 |
| 140 | U-100 | 6 |
| UPN | | |
| 393 | UPN 80 | 18 |
| 394 | UPN 100 | 6 |



**Chapa hexagonal para rodillo guía | Hexagonal
plate for guide roller | Plaque hexagonale pour
coussinet guide | Chapa hexagonal rolo guia**

| Cod. | Medidas - Dimensions | |
|--------------|---|---|
| Hexagonal 27 | | |
| 150 | Para For Pour Cod.1351 Cod.135 Cod.136 | 1 |
| Hexagonal 32 | | |
| 151 | Para For Pour Cod.141 Cod.137 Cod.138 Cod.139 Cod.393 Cod.394 | 1 |

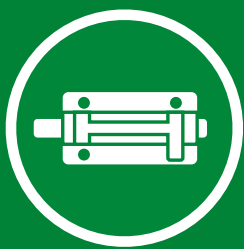

Cerrojos y Pasadores

Bolts and Squared Bolts

Verrous et Verrous Carrés

Ferrolhos e Passadores

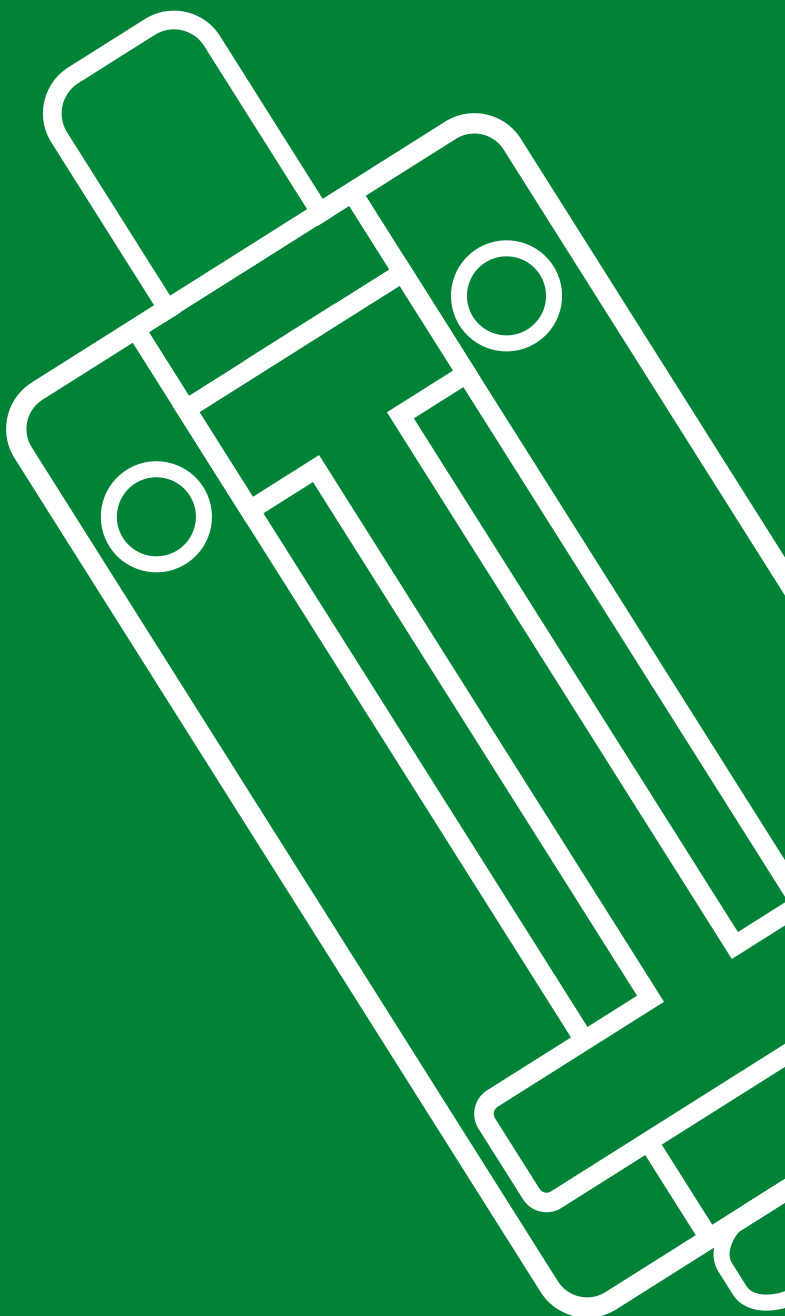

ES

Cerrojos de atornillar
Cerrojos con solapa
Cerrojos de soldar
Pasadores cuadrados con muelle
Pasadores

EN

Barrel Bolt latch to screw
Barrel Bolt latch with flap to weld
Barrel Bolt latch to weld
Square barrel bolt latch
Flush bolts

FR

Verrou rond à visser
Verrou rond avec pattes à souder
Verrou rond à souder
Verrou carré à ressort
Verrou à levier

PO

Ferrolho de aparafusar
Ferrolho com solapa
Ferrolho soldar
Passador quadrado com mola
Passador

A
CERO
STEEL
ACIER
AÇO

I
NOX
STAINLESS
STEEL

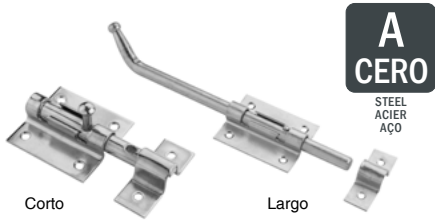

A
CERO
STEEL
ACIER
AÇO

Corto

Largo

Cercojo de atornillar | Barrel Bolt latch to screw | Verrou rond à visser acier | Ferrolho de aparafusar aço

| Cod. | Medidas - Dimensions | |
|------------------------------|----------------------|----|
| Corto Short Court | | |
| 176 * | 70 mm | 10 |
| 177 * | 85 mm | 10 |
| 178 * | 100 mm | 10 |
| 179 * | 120 mm | 10 |
| Largo Long Long | | |
| 182 | 200 mm | 10 |
| 183 | 250 mm | 5 |
| 184 | 300 mm | 5 |
| 185 | 400 mm | 5 |
| 186 | 500 mm | 5 |
| 189 | 600 mm | 5 |

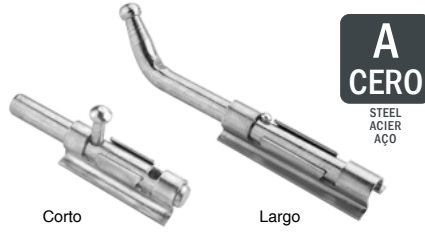

A
CERO
STEEL
ACIER
AÇO

Corto

Largo

Cercojo con solapa | Barrel Bolt latch with flap to weld | Verrou rond avec pattes à souder acier | Ferrolho com solapa aço

| Cod. | Medidas - Dimensions | |
|------------------------------|----------------------|----|
| Corto Short Court | | |
| 156 * | 70 mm | 15 |
| 153 * | 85 mm | 15 |
| 154 * | 100 mm | 15 |
| 155 * | 120 mm | 12 |
| Largo Long Long | | |
| 157 | 200 mm | 15 |
| 158 | 300 mm | 10 |
| 149 | 400 mm | 10 |
| 148 | 600 mm | 10 |

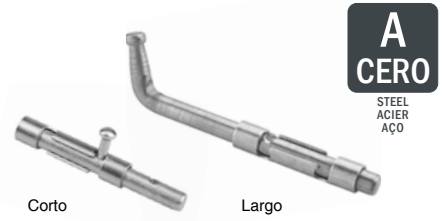

A
CERO
STEEL
ACIER
AÇO

Corto

Largo

Cercojo de soldar | Barrel Bolt latch to weld | Verrou rond à souder acier | Ferrolho soldar aço

| Cod. | Medidas - Dimensions | |
|------------------------------|----------------------|----|
| Corto Short Court | | |
| 190 * | 85 mm | 15 |
| Largo Long Long | | |
| 191 | 200 mm | 15 |
| 192 | 400 mm | 10 |
| 193 | 600 mm | 10 |



PULIDO
POLISHED | POLI
SATINADO
SATIN | SATINÉ
NOX
AISI 316

Cercojo de atornillar | Stainless steel barrel bolt latch to screw | Verrou rond à visser inox | Ferrolho de parafusar inox

| Cod. | Medidas - Dimensions | |
|--|----------------------|------------------|
| Inox Stainless Steel | | |
| Pulido Polished Poli Polido | | |
| 176P * | 70 mm | Corto Short 10 |
| 177P * | 85 mm | Corto Short 10 |
| 1785P * | 110 mm | Corto Short 8 |
| 182P | 200 mm | Largo Long 6 |
| 184P | 300 mm | Largo Long 6 |
| 185P | 400 mm | Largo Long 6 |
| Satinado Satin Satiné Acetinado | | |
| 176S * | 70 mm | Corto Short 10 |
| 177S * | 85 mm | Corto Short 10 |
| 1785S * | 110 mm | Corto Short 8 |
| 182S | 200 mm | Largo Long 6 |
| 184S | 300 mm | Largo Long 6 |
| 185S | 400 mm | Largo Long 6 |



PULIDO
POLISHED | POLI
SATINADO
SATIN | SATINÉ
NOX
AISI 316

Cercojo con solapa | Stainless steel barrel bolt latch with flap to weld | Verrou rond avec pattes à souder inox | Ferrolho com solapa inox

| Cod. | Medidas - Dimensions | |
|--|----------------------|------------------|
| Inox Stainless Steel | | |
| Pulido Polished Poli Polido | | |
| 156P * | 70 mm | Corto Short 10 |
| 153P * | 85 mm | Corto Short 10 |
| 1545P * | 110 mm | Corto Short 8 |
| 157P | 200 mm | Largo Long 6 |
| Satinado Satin Satiné Acetinado | | |
| 156S * | 70 mm | Corto Short 10 |
| 153S * | 85 mm | Corto Short 10 |
| 1545S * | 110 mm | Corto Short 8 |
| 157S | 200 mm | Largo Long 6 |



A
CERO
STEEL
ACIER
AÇO

Pasador cuadrado con muelle | Square barrel bolt latch with spring | Verrou carré à ressort | Passador quadrado com mola aço

| Cod. | Medidas - Dimensions | |
|------|----------------------|-----------------------|
| 659 | 150 mm | Condena + Tornillo 10 |
| 637 | 200 mm | Condena + Tornillo 10 |
| 663 | 250 mm | Condena + Tornillo 10 |
| 646 | 300 mm | Condena + Tornillo 10 |
| 649 | 400 mm | Condena + Tornillo 10 |
| 652 | 500 mm | Condena + Tornillo 10 |
| 653 | 600 mm | Condena + Tornillo 10 |
| 656 | 800 mm | Condena + Tornillo 10 |



PULIDO
POLISHED | POLI
NOX
AISI 304

Pasador inox cuadrado con muelle | Stainless steel square barrel bolt latch with spring | Verrou carré à ressort inox | Passador quadrado com mola inox

| Cod. | Medidas - Dimensions | |
|--|----------------------|-----------------------|
| Inox Stainless Steel | | |
| Pulido Polished Poli Polido | | |
| 637I | 200 mm | Condena + Tornillo 10 |
| 646I | 300 mm | Condena + Tornillo 10 |
| 649I | 400 mm | Condena + Tornillo 10 |



A
CERO
STEEL
ACIER
AÇO

Pasador de acero | Steel bluish bolt | Verrou à levier acier | Passador aço

| Cod. | | |
|------|----------------------------------|----|
| 194 | Básico Basic Basique | 10 |
| 198 | Fuerte Strong Fort Forte | 10 |
| 199 | Doble acción Double Duplo | 10 |
| 35 | Remate M.8 Plus Vis Rebite | 10 |



FRONTAL PULIDO
POLISHED FRONT | FACE POLIE
NOX
AISI 304

Pasador inox | Stainless steel bluish bolt | Verrou à levier inox | Passador inox

| Cod. | | |
|-------------------------------|-------------------------------|----|
| Inox Stainless Steel | | |
| 1940P | Básico Basic Basique | 10 |
| 1990P | Doble acción Double Duplo | 10 |

* Con taladro para candado | With hole for lock | Avec trou pour cadenas | Com furo para cadeado



Varios

Other products

Produits divers

Vários



ES

Tensor
Cerradura de persiana
Garras para aluminio
Tapones metálicos
Tapones de plástico
Tirador de persiana

EN

Tightener
Lock for roller shutter
Hooks
Metalic end caps
Plastic end caps
Puller

FR

Tendeur
Serrure à volet roulant
Griffes
Bouchons métallique
Bouchons en plastique
Poignée store

PO

Tensor
Fechadura persiana
Garras para alumínio
Tampão de metal
Tampão plástico
Puxador persiana



Tensor
Tightener | Tendeur | Tensor

| Cod. | Acabado | |
|------|-------------------------------|-----|
| 89 | Galvanizado | 275 |
| 870 | Lacado Verde Green Vert | 100 |



Cerradura de persiana y Tirador de persiana
Lock for roller shutter | Serrure à volet roulant |
Fechadura persiana

| Cod. | Acabado | |
|------|---|-----|
| 323 | Galv. Doble Cierre | 1 |
| 180 | Tirador Puller Poignée store Puxador | 200 |

Garras para aluminio
Hooks | Griffes | Garras para aluminio

| Cod. | Medidas - Dimensions | |
|------|----------------------|------|
| 90 | 93x18x0,6 Ligera | 2000 |
| 91 | 97x20x0,8 Reforzada | 1500 |
| 92 | 118x25x0,8 Puerta | 1000 |
| 921 | 120x25x1,5 Especial | 500 |



Tapón redondo metálico | Round metallic end cap |
Bouchon rond métallique |
Tampão redondo metal

| Cod. | Medidas - Dimensions | |
|------|----------------------|-----|
| 75 | 33 mm | 300 |
| 97 | 40 mm | 700 |
| 76 | 42 mm | 700 |
| 98 | 45 mm | 600 |
| 77 | 48 mm | 500 |
| 99 | 50 mm | 500 |
| 78 | 60 mm | 350 |
| 88 | 80 mm | 50 |
| 94 | 90 mm | 40 |

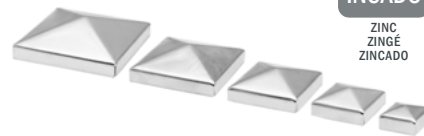

Tapón cuadrado metálico |
Square metallic end cap | Bouchon carré
métallique | Tampão quadrado metal

| Cod. | Medidas - Dimensions | |
|--------|----------------------|-----|
| 98020 | 20x20 Zn | 100 |
| 98030 | 30x30 Zn | 100 |
| 98040 | 40x40 Zn | 200 |
| 98050 | 50x50 Zn | 100 |
| 98060 | 60x60 Zn | 80 |
| 98070 | 70x70 Zn | 70 |
| 98080 | 80x80 Zn | 50 |
| 980100 | 100x100 Zn | 40 |
| 980120 | 120x120 Zn | 50 |
| 980150 | 150x150 Zn | 30 |



Tapón rectangular metálico |
Squared metallic end cap | Bouchon rectangulaire
métallique | Tampão quadrado metal

| Cod. | Medidas - Dimensions | |
|---------|----------------------|-----|
| 972030 | 20x30 Zn | 100 |
| 972040 | 20x40 Zn | 100 |
| 973050 | 30x50 Zn | 100 |
| 973060 | 30x60 Zn | 100 |
| 974060 | 40x60 Zn | 100 |
| 974080 | 40x80 Zn | 100 |
| 9750100 | 50x100 Zn | 60 |



N
EGRO
BLACK
NOIR
PRETO

Tapón redondo plástico | Round plastic end cap |
Bouchon rond plastique | Tampão redondo
plástico

| Cod. | Medidas - Dimensions | |
|------|----------------------|-----|
| 2622 | ∅ 12 mm | 500 |
| 2623 | ∅ 14 mm | 500 |
| 2620 | ∅ 16 mm | 200 |
| 2600 | ∅ 20 mm | 200 |
| 2621 | ∅ 22 mm | 200 |
| 2601 | ∅ 25 mm | 200 |
| 2607 | ∅ 30 mm | 200 |
| 2602 | ∅ 35 mm | 200 |
| 2603 | ∅ 40 mm | 200 |
| 2609 | ∅ 42 mm | 200 |
| 2604 | ∅ 45 mm | 200 |
| 2605 | ∅ 50 mm | 200 |
| 2606 | ∅ 60 mm | 200 |

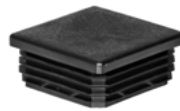

N
EGRO
BLACK
NOIR
PRETO

Tapón cuadrado plástico | Square plastic end cap |
Bouchon carré plastique |
Tampão quadrado plástico

| Cod. | Medidas - Dimensions | |
|-------|----------------------|-----|
| 2589 | 16x16 mm | 100 |
| 2590 | 20x20 mm | 100 |
| 25901 | 25x25 mm | 100 |
| 2591 | 30x30 mm | 100 |
| 25911 | 35x35 mm | 200 |
| 2592 | 40x40 mm | 50 |
| 2580 | 45x45 mm | 100 |
| 2593 | 50x50 mm | 30 |
| 2596 | 60x60 mm | 20 |
| 25950 | 70x70 mm | 50 |
| 2594 | 80x80 mm | 15 |
| 2595 | 100x100 mm | 10 |



N
EGRO
BLACK
NOIR
PRETO

Tapón rectangular plástico | Rectangulaire plastic
end cap | Bouchon carré plastique | Tampão
quadrado plástico

| Cod. | Medidas - Dimensions | |
|-------|----------------------|-----|
| 25902 | 30x20 mm | 100 |
| 2613 | 40x20 mm | 300 |
| 2597 | 40x30 mm | 200 |
| 25900 | 50x20 mm | 100 |
| 25990 | 50x30 mm | 100 |
| 2581 | 50x40 mm | 100 |
| 2599 | 60x30 mm | 100 |
| 2608 | 60x40 mm | 100 |
| 2598 | 80x40 mm | 100 |
| 2612 | 100x40 mm | 50 |
| 2610 | 100x50 mm | 50 |
| 2611 | 120x60 mm | 50 |



B
LANCO
WHITE
BLANC
BRANCO

Tapón redondo plástico blanco | White round
plastic end cap | Bouchon rond plastique blanc |
Tampão redondo plástico branco

| Cod. | Medidas - Dimensions | |
|-------|----------------------|-----|
| 2622B | ∅ 12 mm | 500 |
| 2623B | ∅ 14 mm | 500 |
| 2620B | ∅ 16 mm | 200 |



B
LANCO
WHITE
BLANC
BRANCO

Tapón cuadrado plástico blanco | White square
plastic end cap | Bouchon carré plastique blanc |
Tampão quadrado plástico branco

| Cod. | Medidas - Dimensions | |
|--------|----------------------|-----|
| 2590B | 20x20 mm | 100 |
| 25901B | 25x25 mm | 100 |
| 2591B | 30x30 mm | 100 |
| 2592B | 40x40 mm | 50 |
| 2593B | 50x50 mm | 30 |
| 2596B | 60x60 mm | 20 |
| 2594B | 80x80 mm | 15 |



B
LANCO
WHITE
BLANC
BRANCO

Tapón rectangular plástico blanco | White
rectangular plastic end cap | Bouchon rectangulaire
plastique blanc | Tampão quadrado plástico branco

| Cod. | Medidas - Dimensions | |
|-------|----------------------|-----|
| 2613B | 40x20 mm | 300 |
| 2599B | 60x30 mm | 100 |
| 2608B | 60x40 mm | 100 |
| 2598B | 80x40 mm | 100 |
| 2610B | 100x50 mm | 50 |



Manillas y Tiradores inox

Stainless Steel Handles

Béquilles et Poignées inox

Manilhas e Puxadores aço inox

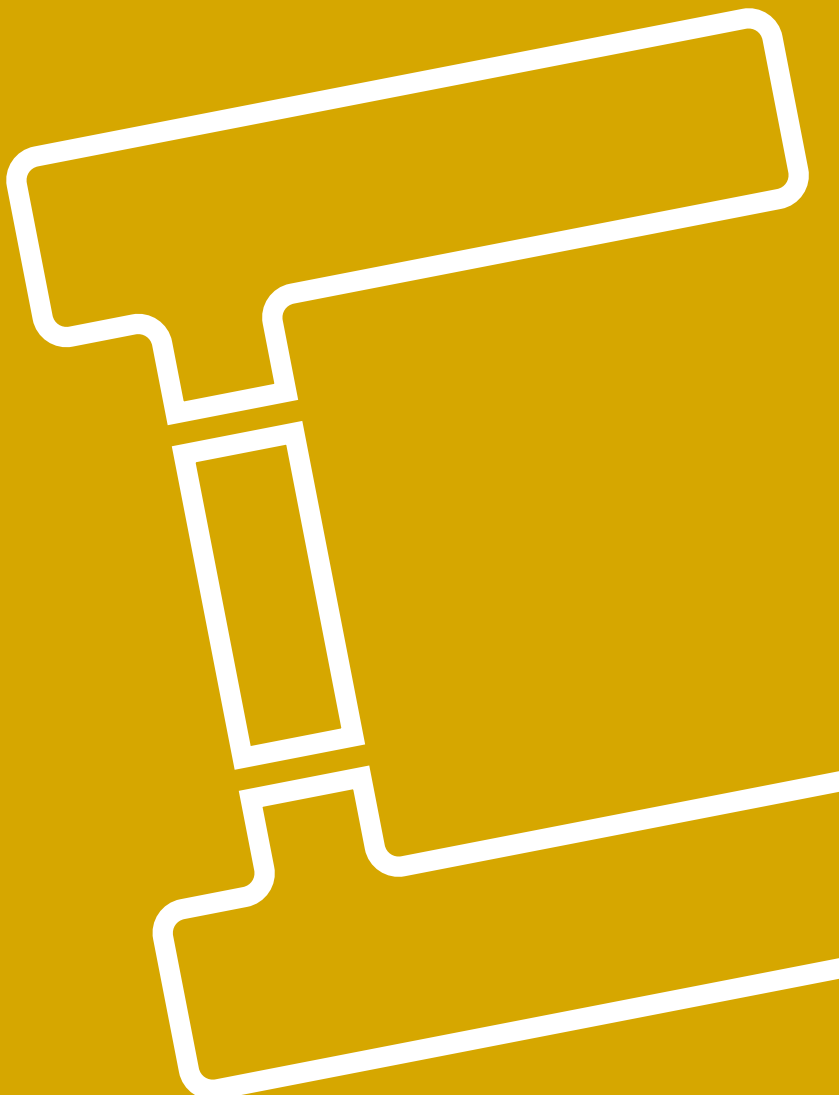

Manillas
Bocallave
Tiradores
Rosetas
Juego de abrazaderas
Tubo



Handles
Round escutcheons
Tubing pull handles
Rosettes
Sets of brace supports
Tube



Poignées rosace ronde
Trou de serrure
Poignées
Rosaces
Jeu de supports anneaux
Tube



Manilha
Escudete de chave redondo
Puxadors
Rosetas
Jogo de suportes abraçadeira
Tubo





I
NOX

STAINLESS
STEEL

Manilla modelo 1 ovalado | Lever handle round rosette | Béquille rosace ronde | Manilha redondo

| Cod. | Medidas - Dimensiones | |
|--|-----------------------|-------|
| Todo inox All in SS Tout en inox Todo em inox | | |
| 9920TOP | AISI 304 PUL | 1 set |
| 9920OS | AISI 304 SAT | 1 set |



I
NOX

STAINLESS
STEEL

Manilla modelo 2 ovalado | Lever handle oval rosette | Béquille rosace ovale | Manilha oval

| Cod. | Medidas - Dimensiones | |
|--|-----------------------|-------|
| Todo inox All in SS Tout en inox Todo em inox | | |
| 9921TOP | AISI 304 PUL | 1 set |
| 9921TOS | AISI 304 SAT | 1 set |



I
NOX

STAINLESS
STEEL

9980CS

9980DP
9980DS

Bocallave redonda | Round escutcheon | Rosace clé ronde | Escudete de chave redondo

| Cod. | Medidas - Dimensiones | |
|--------|-----------------------|---|
| 9980CS | AISI 304 SAT | 1 |
| 9980DP | AISI 304 PUL | 1 |
| 9980DS | AISI 304 SAT | 1 |



Simple

Set

I
NOX

STAINLESS
STEEL

Tirador modelo 5 | Tubing pull handle model 5 | Poignée modèle 5 | Puxador modelo 5

| Cod. | Medidas - Dimensiones | |
|---------|-----------------------|-------|
| 9931P04 | Set AISI 304 PUL | 1 set |
| 9931P16 | Set AISI 316 PUL | 1 set |
| 9931S04 | Set AISI 304 SAT | 1 set |
| 9939P04 | Simple AISI 304 PUL | 1 |
| 9939S04 | Simple AISI 304 SAT | 1 |



Simple

Set

I
NOX

STAINLESS
STEEL

Tirador modelo 15 | Tubing pull handle model 15 | Poignée modèle 15 | Puxador modelo 15

| Cod. | Medidas - Dimensiones | |
|---------|-----------------------|-------|
| 9933P04 | Set AISI 304 PUL | 1 set |
| 9933S04 | Set AISI 304 SAT | 1 set |
| 9941P04 | Simple AISI 304 PUL | 1 |
| 9941S04 | Simple AISI 304 SAT | 1 |



I
NOX

STAINLESS
STEEL

Asa tirador | Tubing pull handle | Poignée | Axa puxador

| Cod. | Medidas - Dimensiones | |
|-------|-----------------------|---|
| 9970S | AISI 304 SAT | 5 |



Rosetas - Embellecedores | Rosettes | Rosaces | Rosetas-Tampão

| Cod. | Medidas - Dimensiones | |
|-------|-----------------------|---|
| 9946P | Cromo - PUL | 1 |
| 9946S | Niquel - SAT | 1 |



Tubo 40 mm | Tube 40 mm | Tube 40 mm | Tubo 40 mm

| Cod. | Medidas - Dimensiones | |
|-------------------------------|-----------------------|--------|
| Inox Stainless Steel | | |
| T401525P04 | INOX 304 PUL | 2,25 m |
| T401525S04 | INOX 304 SAT | 2,25 m |
| T401550P04 | INOX 304 PUL | 2,50 m |
| T401550S04 | INOX 304 SAT | 2,50 m |
| Inox Stainless Steel | | |
| AISI 316 | | |
| T401525P16 | INOX 316 PUL | 2,25 m |
| T401525S16 | INOX 316 SAT | 2,25 m |
| T401550P16 | INOX 316 PUL | 2,50 m |
| T401550S16 | INOX 316 SAT | 2,50 m |



Juego abrazaderas simples 40 mm | Set of brace supports for 40 mm tube | Jeu de supports anneaux pour tube 40 mm | Jogo de suportes abraçadeira para tubo 40 mm

| Cod. | Medidas - Dimensiones | |
|----------|---|--|
| 99100P03 | INOX 303 PUL 1 Juego Set Jeu Jogo | |
| 99100S03 | INOX 303 SAT 1 Juego Set Jeu Jogo | |
| 99220P16 | INOX 316 PUL 1 Juego Set Jeu Jogo | |
| 99220S16 | INOX 316 SAT 1 Juego Set Jeu Jogo | |



I
NOX

STAINLESS
STEEL

Juego abrazaderas dobles 40 mm | Set of brace supports for 40 mm tube | Jeu de supports anneaux pour tube 40 mm | Jogo de suportes abraçadeira para tubo 40 mm

| Cod. | Medidas - Dimensiones | |
|----------|---|--|
| 99110P03 | INOX 303 PUL 1 Juego Set Jeu Jogo | |
| 99110S03 | INOX 303 SAT 1 Juego Set Jeu Jogo | |
| 99230P16 | INOX 316 PUL 1 Juego Set Jeu Jogo | |
| 99230S16 | INOX 316 SAT 1 Juego Set Jeu Jogo | |

Seguridad y Compromiso

Security and Commitment | Sécurité et Engagement |
Segurança e Empenhamento

Software propio de asesoramiento

Own consultancy software | Logiciel de conseil interne | Software de consultoria interna



ES ¿Qué ofrece nuestro Software?

Conociendo las características básicas de una puerta, como peso y dimensiones, proponemos la solución más óptima:

- Qué elementos debe colocar (tipo y tamaño).
- A qué distancias fijarlos.

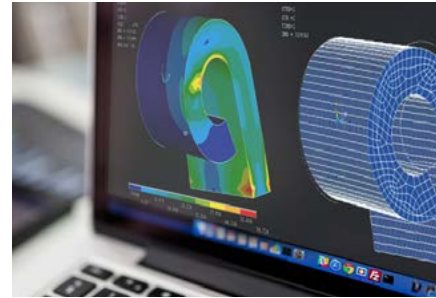

EN What does our software offer?

Knowing the basic characteristics of a door, such as weight and dimensions, we propose the most optimal solution:

- Which elements to fit (type and size).
- At what distances to fix them.

FR Que propose notre logiciel ?

Connaissant les caractéristiques de base d'une porte, telles que le poids et les dimensions, nous proposons la solution la plus optimale:

- Quels éléments installer (type et taille).
- À quelles distances les fixer

PO O que é que o nosso software oferece?

Conhecendo as características de base de uma porta, como o peso e as dimensões, propomos a solução mais adequada:

- Quais os elementos a colocar (tipo e tamanho).
- Que distâncias os fixar.

Centro de ensayos propio

Own test centre | Propre centre d'essai | Centro de testes próprio



ES Testamos nuestros productos

Testamos nuestros herrajes y sistemas para poder determinar su **vida útil, peso máximo soportado y resistencia**, entre otras variables. Un valor añadido a la calidad de nuestros productos.

EN We test our fittings

We test our fittings and systems to determine their **useful life, maximum supported weight and resistance**, among other variables. An added value to the quality of our products.

FR Nous testons nos produits

Nous testons nos produits et nos systèmes afin de déterminer leur **durée de vie, leur poids maximal supporté et leur résistance**, entre autres variables. Une valeur ajoutée à la qualité de nos produits.

PO Testamos os nossos produtos

Testamos os nossos acessórios e sistemas para determinar **a sua vida útil, peso máximo suportado e resistência**, entre outras variáveis. Uma mais-valia para a qualidade dos nossos produtos.

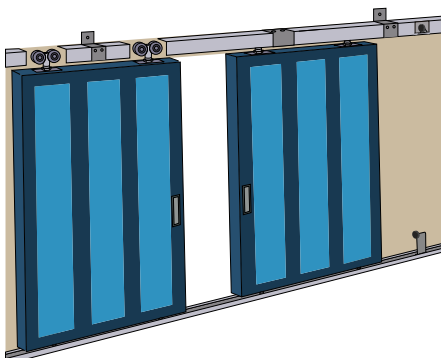

Asesoramiento técnico

Technical advice | Conseils techniques | Aconselhamento técnico

- Contacte con Estebro para resolver sus dudas o pedir consejo sobre sus instalaciones y proyectos.
- Contact Estebro to solve your doubts or ask for advice about your installations and projects.
- Contactez Estebro pour résoudre vos doutes ou demander des conseils sur vos installations et projets.
- Entre em contato com a Estebro para tirar suas dúvidas ou pedir assessoria em suas instalações e projetos.



- ¿Doubts? Ask our Technical Dept.
- ¿Avez vous des doutes? notre service technique se fera un plaisir de vous conseiller.

Estebro Online

Siempre conectados | Always connected | Toujours en contact | Sempre ligado

www.estrobro.es

- Fotos, planos y tablas de información
- Buscador de referencias
- Descarga de catálogos y folletos
- Videotutoriales
- Noticias y artículos de interés

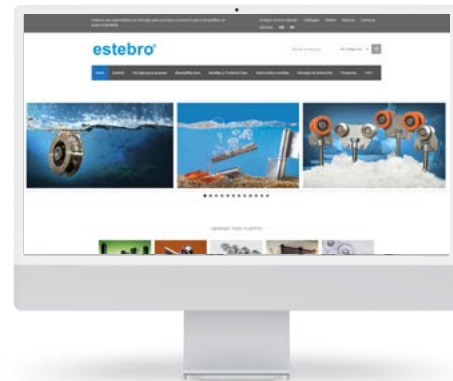

www.estrobro.fr

- Photos, plans et tableaux d'information
- Recherche de références
- Télécharger des catalogues et des brochures
- Vidéos tutorielles
- Information et articles d'intérêt

www.estrobro.co.uk

- Photos, drawings and information tables
- Reference search engine
- Catalogues and brochures downloads
- Videotutorials
- News and articles of interest



www.estebro.es



Estampaciones EBRO, S.L.
Pol. Ind. Malpica-Alfindén | C/H, 10-12-14-5
50171 La Puebla de Alfindén, Zaragoza, ESPAÑA



Tel.: (34) 976 107 288
Fax: (34) 976 108 058



estebro@estebro.es